



FIREHAWK



**40CM KAMADO GRILL
FHAWKKAM16G
OWNER'S MANUAL**

Kamado Grill

User Instructions-Please keep for future reference

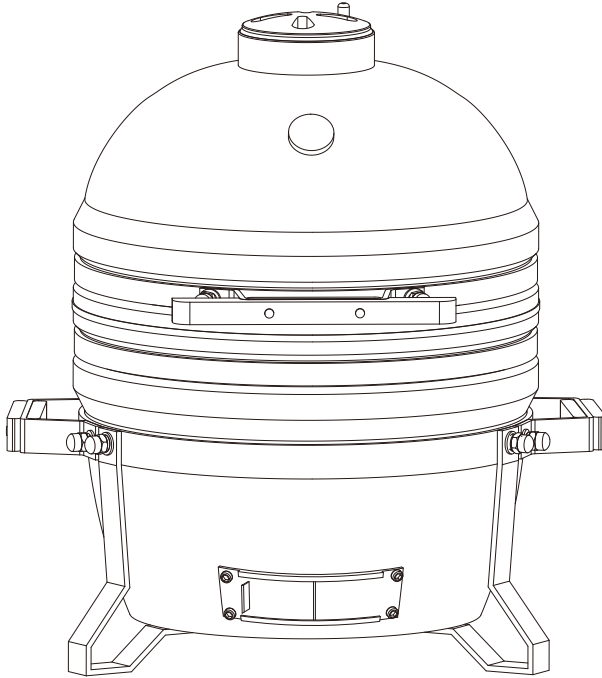

IMPORTANT-Carefully remove any packaging before use, but retain the safety instructions.

These instructions form part of the product.

Please take note of all of the safety warnings listed in these instructions.

Please read these instructions in their entirety and retain them for future reference.

These instructions should be stored with the product.

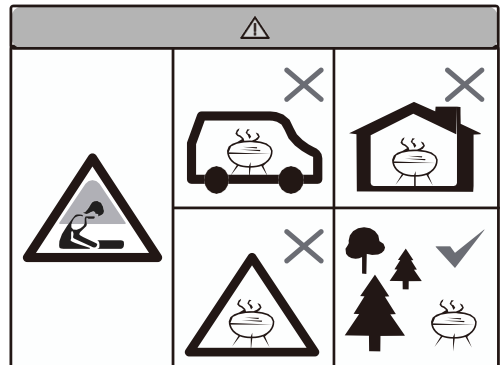

STRICTLY FOR OUTDOOR USE ONLY

ABOUT THE KAMADO

The history of Kamado dates back to 3000 years ago in Asia and to this day are still based on the same basic principals of cooking over hot coals in a stone vessel. The main material of your Firehawk Kamado grill is ceramic clay, which delivers extremely high thermal insulation performance.

The Firehawk Kamado is a versatile BBQ grill & smoker that you can use not only for grilling but also for baking, or long slow smoking (smoker). Kamado grill is great at holding heat and smoke inside the vessel enhancing the flavor of your food further.

Best fuel is lump charcoal burnt on the on the fire grate or charcoal basket within the firebox. This delivers even heat for foods which are cooked on the upper cooking grids. Airflow circulates from bottom vent to top vent and the grill thermometer on the ceramic dome will show you the inside cooking temperature.

By adjusting the bottom vent and top vent to control the airflow, you can get high temperature for searing as well as the low temperature for long and slow cooking over 12 hours.

The ash from burned charcoals will drop through the holes at the fire grate and you can use the ash tool to scrape out the ash from bottom.



WARNING - CAUTION!

- This product is **STRICTLY FOR OUTDOOR USE ONLY**. Do not use indoors.
- Always keep children and pets at a safe distance from the Kamado when in use.
- Never leave a burning fire unattended.
- Danger of carbon monoxide poisoning. Never light this product or let it smolder or cool down in confined spaces.
- Do not use this product in a tent, caravan, campervan, car or boat.
- Do not use under any awnings, parasols or gazebos.
- Fire hazard: Hot embers may emit sparks while in use.
- Caution: Do not use petrol, white spirit, lighter fluid, alcohol or other similar chemicals for lighting or relighting..
- It is highly recommended that you use lump charcoal in your Kamado. It burns for longer and produces less ash which can otherwise restrict the airflow. Do not use coal in this product.
- Important: When opening the dome at high temperatures it is essential to lift the dome only slightly, allowing air to enter slowly and safely to prevent any backdraft or flare-ups that may cause injury.
- Do not use the Kamado on decking or any other flammable surfaces such as dry grass, woodchips, leaves or decorative bark.
- Ensure that the Kamado is positioned at least 2 meters away from flammable items.
- Do not use this Kamado as a furnace.
- Attention: This product will become very hot. Do not move it during operation.
- Always use heat resistant gloves when handling hot ceramics or cooking surfaces.
- Allow the unit to cool down completely before moving or storing.
- Always inspect the unit prior to use for fatigue and damage and replace as and when necessary.



CURING THE KAMADO

- To start a fire place rolled up newspaper with some lighter cubes or solid firelighters on the charcoal plate or in basket in the base of the Kamado. Then place 2 or 3 handfuls of lump charcoal over the top of the newspaper.
- Do not use petrol, white spirit, lighter fluid, alcohol or other similar chemicals for lighting or re-lighting.
- Open the bottom vent and light the paper using a long nosed lighter or safety matches.
- Do not overload the unit with fuel. If the fire is too intense this could damage the Kamado.
- Leave until all the fuel is used and extinguished.
- If the first burns are too high it could damage the gasket seal before it has had the chance to mature properly.
- **IMPORTANT:** After first use inspect all fasteners for tightness. The metal band connecting your lid to the base will expand from the heat and this could become loose. It is recommended you check and if necessary tighten the band with a spanner.
- You can now use your Kamado as normal.



LIGHTING, USAGE AND CARE INFORMATION

- After initial curing ensure the Kamado is positioned on a permanent, flat, level, heat resistant non-flammable surface away from flammable items.
- Ensure the Kamado has a minimum of 2m overhead clearance and has a minimum 2m clearance from other surrounding items.
- To start a fire place rolled up newspaper with some lighter cubes or solid firelighters on the charcoal plate in the base of the Kamado. Then place 2 or 3 handfuls of lump charcoal over the top of the newspaper.
- Do not use petrol, white spirit, lighter fluid, alcohol or other similar chemicals for lighting or re lighting.
- Open the bottom vent and light the paper using a long nosed lighter or safety matches. Once it has caught, leave the bottom vent and dome open for about 10 minutes to build a small bed of hot embers.
- Allow the charcoal to heat up and be kept red hot for at least 30 minutes prior to the first cooking on the Kamado. Do not cook before the fuel has a coating of ash.
- It is recommended you do not stoke or turn the coals once they are alight. This allows the charcoals to burn more uniformly and efficiently.
- Once alight only use heat resistant gloves when handling hot ceramics or cooking surfaces.

EXTINGUISHING

- To extinguish unit stop adding fuel and close all the vents and the dome to allow the fire to die naturally.
- Do not use water to extinguish the charcoals as this could damage the ceramic Kamado.

STORAGE

- When not in use, and if stored outside cover the Kamado once completely cooled with a suitable rain cover.
- The stainless steel cooking grill is not dishwasher safe; use a mild detergent with warm water.
- When using the Kamado push down on both of the locking wheels to stop the unit moving about during use.
- It is recommended the Kamado be stored under cover in a garage or shed when not in use.

CLEANING

- The Kamado is self cleaning. Heat it up to 260°C for 30 minutes and it will scorch off all of the food and debris.
- Do not use water or any other types of cleaning product to clean the inside of your Kamado. The walls are porous and will absorb any fluids used, this could cause the Kamado to crack. If the soot becomes excessive then use a wire brush or the ash tool (not supplied) to scrape off the carbon remnants before the next use.
- To clean the grills and grates use a non-abrasive cleaner once the unit has fully cooled.
- To clean the outer surface wait until the Kamado is cool and use a damp cloth with a mild detergent.

MAINTENANCE

- Tighten the bands and oil the hinge 2 times a year or more if needed.

Parts list

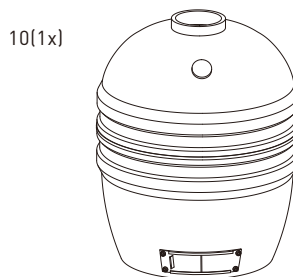
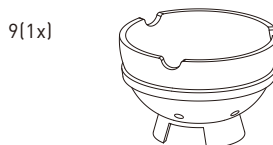
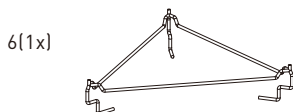
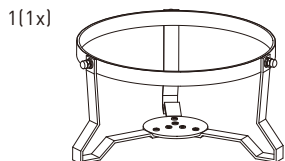

- Prior to assembly, read the instructions carefully. Check all parts against the parts list.
- Carry out assembly on a soft surface to avoid scratching the paint. Please retain this information for future reference.
- For ease of assembly only loosely tighten bolts and then tighten fully when assembly is complete.
- **WARNING - DO NOT** over tighten bolts; only tighten with moderate pressure to avoid damaging the bolts or components of your Kamado Grill.

Step 1:

Put the Kamado's ceramic body(10) into the assembled tripod-frame(1) and carefully adjust to the most appropriate position.

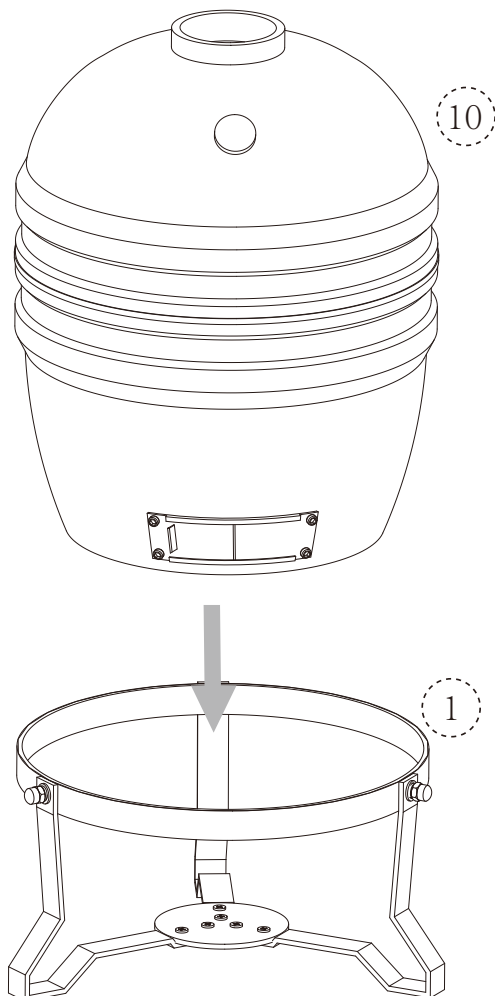

Step 2:

Install the front handle(2) to the dome of the Kamado. Start by attaching handle brackets with the flat mats(a), spring washers(b), and dome-headed nuts(c) in turn.

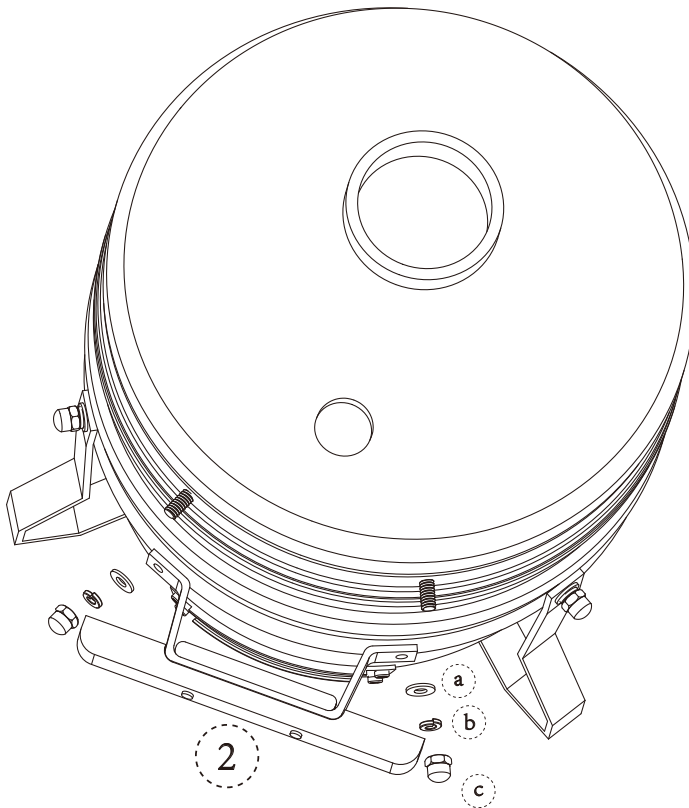

Step 3:

Install the handles(3) on both sides to the ring of tripod-frame(1), by using the operation similar to step 2.

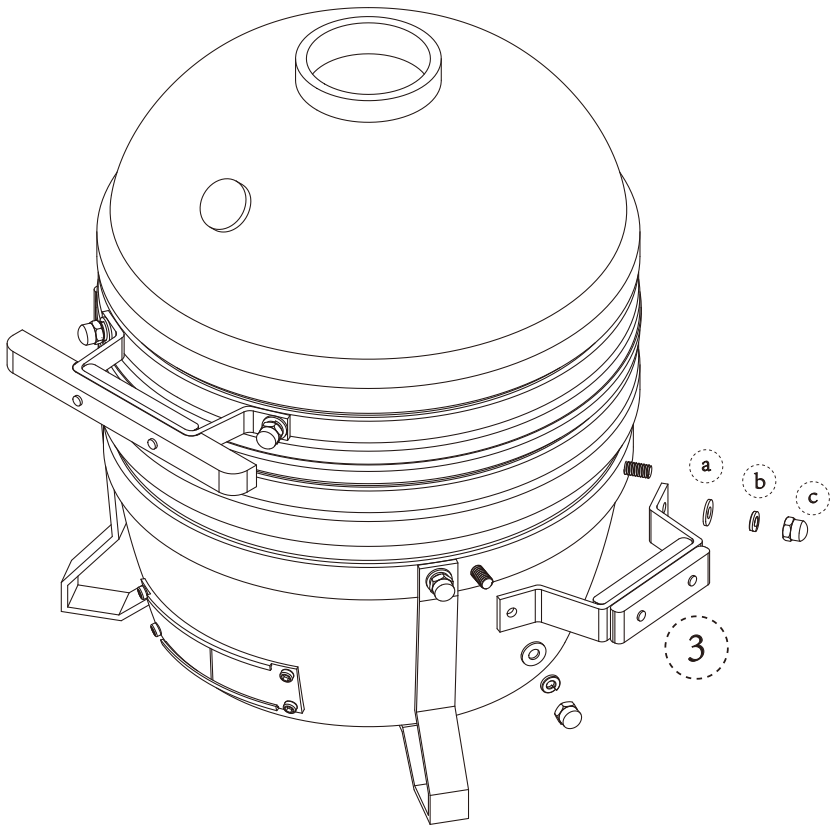

Step 4:

Install the top vent(4) to the Kamado's ceramic body(10) and place it on the top. Ensure that the gear mark of the top vent(4) should be directly in front of the thermometer and handle alignment.

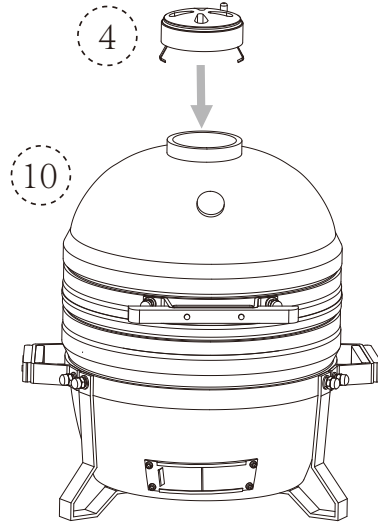

Step 5:

Open the dome and add the firebox(9), charcoal plate(8), tripod rack(6), full-moon pizza stone(7) and cooking gird(5) inside of the Kamado as displayed in the assembly diagram.

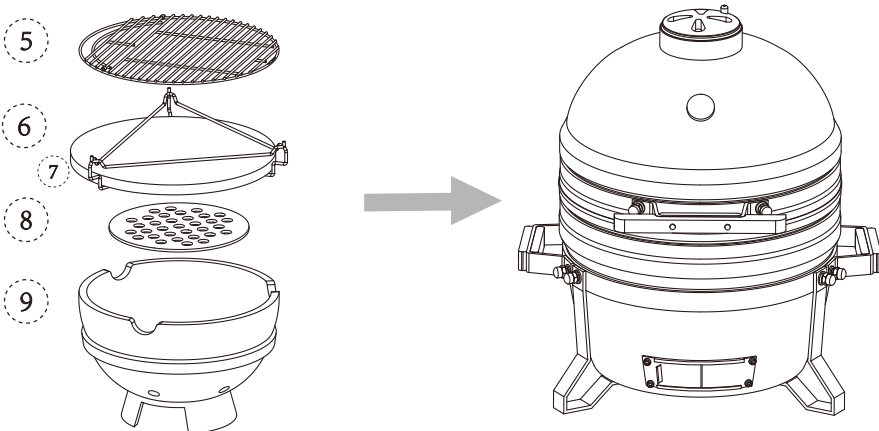

Your Firehawk Kamado is now ready for use



FIREHAWK

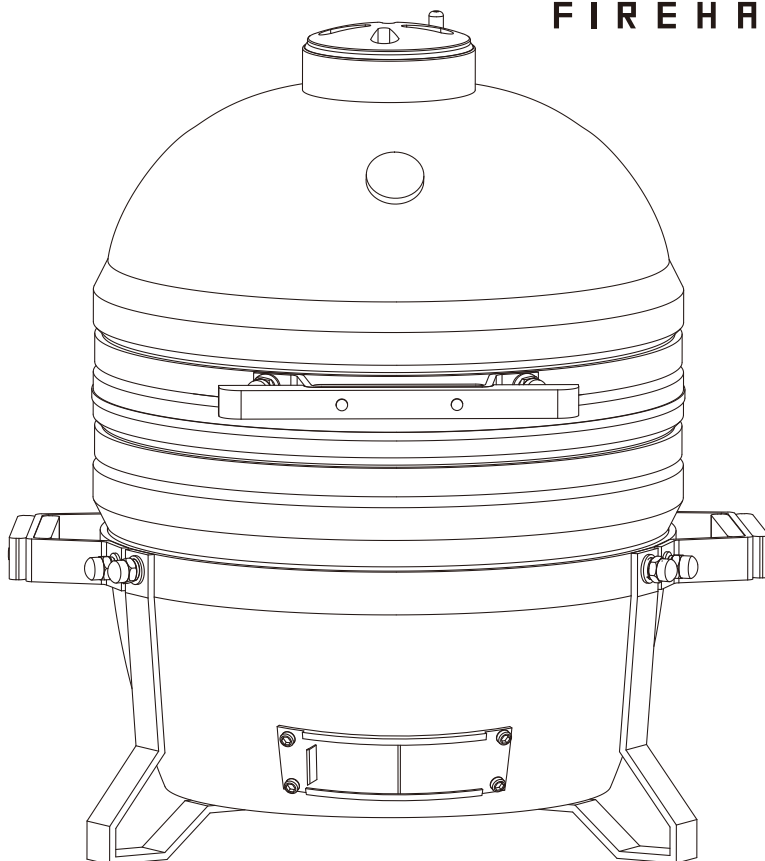

Cooking Tips

LOW TEMPERATURE COOKING GUIDE

- Light the lump charcoal according to the instructions above.
- **DO NOT** move or stoke the coals once lit.
- Open the bottom vent fully and leave the lid open for about 10 minutes to build a small bed of hot embers. Monitor the Kamado until it has risen to the desired temperature. (Refer temperature cooking guide). Leave the bottom vent just slightly open.
- **IMPORTANT:** When opening the lid at high temperatures it is essential to lift the lid initially only slightly, allowing air to enter slowly and safely, preventing any backdraft or flare-ups that may cause injury.
- We recommend use of heat resistant gloves when handling hot ceramics or cooking surfaces.
- The bottom vent gives coarse control over the fire. With the bottom vent set correctly, the top vent gives fine control over the fire. If adjusting the top vent has no response, then the bottom vent or fuel amount needs adjustment.

SMOKING GUIDE

- Follow the instructions above as if you were starting a slow cook.
- Monitor the Kamado until it has risen to the desired temperature. (Refer temperature cooking guide). Leave the bottom vent slightly open.
- Close the top vent and continue to check the temperature for a few more minutes. Using heat resistant gloves sprinkle the wood chips in a circle over the hot charcoal. You are now ready to use the Kamado to smoke on.
- **TIP:** Soak your wood chips or cooking planks in water for 15 minutes to prolong the smoking process.
- **IMPORTANT:** When opening the lid at high temperatures it is essential to lift the lid initially only slightly, allowing air to enter slowly and safely, preventing any backdraft or flare-ups that may cause injury.
- We recommend use of heat resistant gloves when handling hot ceramics or cooking surfaces.
- The bottom vent gives coarse control over the fire. With the bottom vent set correctly, the top vent gives fine control over the fire. If adjusting the top vent has no response, then the bottom vent or fuel amount needs adjustment.

HIGH TEMPERATURE COOKING GUIDE

- Light the lump charcoal according to the the instructions on page3
- Close the lid and fully open the top and bottom vents.
- Monitor the Kamado until it has risen to the desired temperatureSee refer page 15 for a temperature cooking guide.
- Close the top vent half way and continue to check the temperature for a few more minutes
- You are now ready to use the Kamado for cooking on
- **IMPORTANT:**When opening the lid at high temperatures it is essential to lift the lid initially only slightly, allowing ait to enter slowly and safely, preventing any backdraft or flare-ups that may cause injury.

FOOD COOKING INFORMATION



- **DO NOT** cook until the lit fuel has a coating of ash.
- Please read and follow this advice when cooking on your Kamado.
- Always wash your hands before and after handling uncooked meat and before eating.
- Always keep raw meat away from cooked meat and other foods.
- Before cooking ensure all surfaces and tools are clean and free of old food residues.
- **DO NOT** use the same utensils to handle cooked and uncooked foods Ensure all meat is cooked thoroughly before eating.
- **CAUTION** - eating raw or under cooked meat can cause food poisoning (e.g.bacteria strains such as E.coli) .
- To reduce the risk of under cooked meat use a temperature probe to check internal temperature.
- After cooking on your Kamado always burn off and clean the grill cooking surfaces and utensils.

REFUELLING

- With the vents closed,the Kamado stays at a high temperature for several hours. If you require a longer cooking time (e.g when roasting a whole joint or slow smoking), it may be necessary to add more charcoal. Just add some additional charcoal and continue as above.

Open Closed

COOKING TEMPERATURE GUIDE

Slow cook / Smoke (110°C-135°C)		Top Vent Setting	Bottom vent
Beef Brisket	2 Hrs per 500 grams	Level 1	
Pulled Pork	2 Hrs per 500 grams		
Whole Chicken	3-4 Hr.		
Ribs	3-5 Hrs.		
Roasts	9+ Hrs.		
Grill / Roast (160°C-180°C)		Top Vent Setting	Bottom vent
Fish	15-20 Min.	Level 2-3	
Pork Tenderloin	15-30 Min.		
Chicken Pieces	30-45 Min.		
Whole Chicken	1-1.5 Hrs.		
Leg of lamb	3-4 Hrs.		
Turkey	2-4 Hrs.		
Ham	2-5 Hrs.		
Sear (260°C-370°C)		Top Vent Setting	Bottom vent
Steak	5-8 Min.	Level 4	
Pork Chops	6-10 Min.		
Burgers	6-10 Min.		
Sausages	6-10 Min.		



WARRANTY AND CONSUMER GUARANTEE

The BBQ's Galore Warranty and consumer guarantees set out in this document override all other warranties on this product.

Barbeques Galore Warranty is provided in addition to other rights and remedies as set out below under 'Consumer Guarantees'.

Warranty Term

Subject to the conditions set out below, this product is warranted to the purchaser to be free from defects in workmanship and materials from the date of purchase for the terms specified below.

5 YEAR- Ceramic body & hood plus firebox against burn through only. Paint deterioration and rust from exposure and normal use are not covered by this warranty. Damage caused by improper operation, lack of cleaning and maintenance or obvious failure to assemble is not covered by this warranty.

1 YEAR- All other parts

Warranty Conditions

1. Barbeques Galore warranty is nontransferable and is limited to the original purchaser.
2. Satisfactory proof of the purchase (as defined in the Competition and Consumer Act 2010 (CCA)) must be furnished at the time of notification of the defect for a claim under this warranty to be enforceable.
3. This warranty covers all parts found to be defective in workmanship and/or materials during the warranty period. Barbeques Galore total liability in respect of a claim by a consumer under the CCA for a minor problem (as defined in the CCA) with a product is limited, at our option, to providing the consumer with a refund, replacement product or repairing the product.
4. For major failures (as the term is defined in the CCA) you are entitled to a replacement or refund and for compensation for any other reasonably foreseeable loss or damage.
5. To implement this warranty, please return the product to the place of purchase or nominated service agent, otherwise a service call out fee will be charged and refunded if claim is warrantable.

Installation Conditions

This appliance is for OUTDOOR USE ONLY!

Warranty Exclusions

1. This warranty will be void and accordingly no claim of any nature will be enforceable if the product has not been assembled, installed or operated according to the instructions, or has been subject to abuse, improperly treated, neglected and/or if any repairs, maintenance or service has been done by an unauthorised person.
2. This warranty does not cover
 - rust due to improper care or lack of maintenance. Contact your place of purchase for care and maintenance instructions. Cool, clean, oil and store covered away from the elements when not in use.
 - commercial use
 - claims arising from damage caused by abrasive chemical cleaners, heat discoloration or fat fires

Consumer Guarantee

Our goods come with guarantees that cannot be excluded under the Australian Consumer Law. You are entitled to a replacement or refund for a major failure and for compensation for any other reasonably foreseeable loss or damage. You are also entitled to have the goods repaired or replaced if the goods fail to be of acceptable quality and the failure does not amount to a major failure.

Subject to the above paragraphs, all express or implied representations, conditions, statutory guarantees, warranties and provisions (whether based on statute, common law or otherwise), relating to this warranty, that are not contained in it, are excluded to the fullest extent permitted by law.

Nothing in this warranty excludes, restricts or modifies any condition, warranty, statutory guarantee, right or remedy, implied or imposed by common law, statute or regulation, which cannot be lawfully excluded, restricted or modified.

For Customer Reference (keep these details filed in a safe place)

Purchased from

Date Purchased () — — — — Record Serial Number _____

N.B. Satisfactory proof of purchase like your sales docket must be kept for any claim under this warranty to be enforceable.

Service Contact Point- Please contact your place of purchase for warranty repairs or service.

BRANCHES AUSTRALIA WIDE

For Customer Care PH: 1300 139 867
or
email: customercare@bbqgalore.com.au

Barbeques Galore Limited,
Build A2, Campus Business Park, 350-374 Parramatta Road, Homebush, NSW 2140
Phone 02 9735 4111