

**Ziegler  
& Brown**

# TRIPLE GRILL

THE COMPLETE BBQ SYSTEM

## OPERATING INSTRUCTIONS



Cart sold separately

Covering Models ZG3GC / ZG3GRC / ZG3GLEC / ZG3GNGC /  
ZG3GRNGC / ZG3GLENGC



# Congratulations on Your Purchase and Welcome to the World of Outdoor Cooking

## **IMPORTANT HEALTH & SAFETY INFORMATION:**

Australia has an excellent safety record when it comes to gas appliances. This reflects both the high quality of appliances sold, as well as growing consumer awareness about safe practice. We urge you to follow these guidelines and instructions for safe use, to prevent overheating and to produce great cooking results.

- Please read these instructions carefully prior to assembly and use. Failure to follow these instructions could lead to serious injury and/or significant damage to property.
- This barbeque is an outdoor appliance only. Under no circumstances should it be used indoors.
- Do not start the barbeque if there is any doubt over the correct assembly, ignition, gas control or safe operation of the unit.
- These instructions should be retained for future reference.
- This barbeque has not been approved for marine use.
- Never attempt to ignite the barbeque with the hood closed.
- Do not perform any servicing on the barbeque yourself. This includes internal adjustment of the regulator and gas valves. Servicing can only be carried out by authorised technicians.
- It is important that you install your barbeque exactly as described in these instructions. In particular you should keep the barbeque clear of combustible material, and you should check for leaks whenever a new connection is made.
- Do not store chemicals or flammable materials near this appliance.
- Do not place articles on or against, or enclose this appliance.
- The barbeque gets extremely hot while in use. Keep children away from the appliance until it has cooled to normal temperatures.
- It is a good idea to tie back long hair and loose clothing while cooking in case of unexpected flare ups.
- Fat fires are the most common cause of problems in barbeques. They are caused by a build up of grease in the drip tray and the inside of the barbeque frame. A fat fire can be difficult to put out, and will be dangerous if it spreads to the gas hose. You should keep your barbeque clean to avoid this occurrence. Fat fires will void the warranty.
- Do not attempt to move or transport the barbeque whilst it is hot. Always allow the barbeque to completely cool down before moving or covering.





- NEVER leave a barbeque unattended with any burners switched on. Always switch **OFF** all burners and cylinders or supply valves when the barbeque is not in use.
- Take care when touching a hot barbeque, especially on surfaces close to the firebox or roasting hood.
- Its fine to pre-heat with all burners on **HIGH** and the hood closed, but NEVER let the temperature on the hood thermometer exceed 250°C.
- When cooking with the hood closed, turn one or more burners to **LOW** or **OFF** as required to keep the barbeque from getting too hot. NEVER let the temperature on the hood thermometer exceed 250°C.
- NEVER leave all burners on **HIGH** for more than 10 minutes, always stay in control by adjusting burners to **LOW** and **OFF** as required to maintain suitable cooking temperatures.
- Follow all manufacturer's instructions to periodically check for gas leaks.
- Flammable materials and liquids must be stored well away from the barbeque.
- Aerosols must not be used near a lit barbeque.
- Gas bottles **MUST** be transported stored and used vertically only.
- Avoid dousing the barbeque with water.
- For safety reasons it is advisable to keep a fire extinguisher and fire blanket close to hand.
- Unsupervised children and the infirm should not be allowed close to the barbeque during pre-heat, cooking, burn off or cooling down of the unit, or at anytime it is connected to the gas supply.
- Please dispose of all polythene packing and plastic bags carefully and keep out of the reach of children.
- Spare or extra gas bottles must **NOT** be stored within close proximity of this barbeque or any other gas or electric appliance.
- Spare or extra gas bottles should not be stored where they are exposed to continuous direct sunlight, as this is a potentially dangerous practice.
- The position of the assembled barbeque should be such that the gas bottle is not left exposed to direct sunlight as this is a potentially dangerous situation.
- For storage and gas cylinder exchange, disconnect the gas cylinder only. Do not disconnect hose from the barbeque.



## Where to Put Your Barbeque

- Please make sure that the barbeque is NOT positioned underneath any combustible material or surface.
- There **MUST** be a clearance of at least 250mm from the sides and the back of the barbeque to any combustible materials or surfaces. There must also be a clearance of at least 1500mm above the cooking surfaces to any combustible surface.
- Flammable materials of any description **MUST** be kept well away from the barbeque.
- The barbeque must be positioned such that the gas bottle is kept away from direct sunlight.
- The barbeque must be positioned to avoid walkways, gangways and general pedestrian access.
- The nature of a barbeque is such that many of the surfaces are hot to touch, the positioning of the barbeque should take into consideration the possibility of accidental hand or body contact.





## Putting your Barbeque in an Enclosure

This appliance must only be used in an above ground, open air situation with natural ventilation, without stagnant areas, where gas leakage and products of combustion are rapidly dispersed by wind and natural convection. **Any enclosure in which the appliance is used must comply with one of the following:**

- An enclosure with walls on all sides, but at least one permanent opening at ground level and no overhead cover. SEE EXAMPLE 1
- Within a partial enclosure that includes an overhead cover and no more than two walls.
- SEE EXAMPLE 2 & 3
- Within a partial enclosure that includes an overhead cover and more than two walls, the following shall both apply: (1) At least 25% of the total wall area is completely open and (2) at least 30% of the remaining wall area is open and unrestricted SEE EXAMPLE 4 & 5
- In the case of balconies, at least 20% of the total of the side, back and front wall areas shall be and remain open and unrestricted

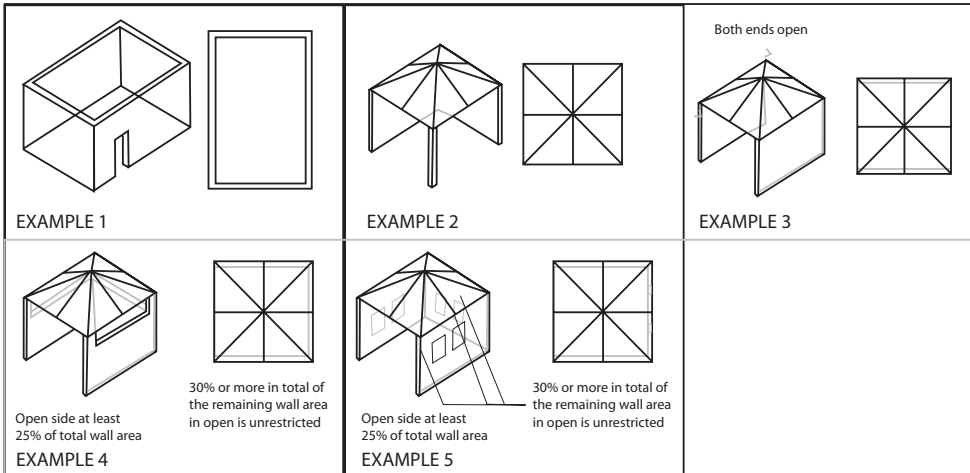



## Installation

- Do not obstruct any ventilation ports on the body of the hood of the barbeque.
- The gas cylinder must be kept out of direct sunlight and away from any heat sources.
- During a gas cylinder swap or refill ensure that all control knobs are in the OFF position and there are no naked flames in close proximity.
- Gas hoses must NOT be twisted, kinked or under any form of tension. The gas hose should hang freely with no bends, folds or kinks.
- No part of the flexible hose should come into contact with any part of the barbeque that will become hot during operation.
- A regular inspection of the hose and 'O' ring seal should be made to ensure that it is not cracking, breaking cutting or deteriorating in any other way.
- Any damage to the hose or 'O' ring seal requires an immediate replacement from your local agent or gas expert.

## Assembling your Barbeque

Start by unpacking the barbeque, and placing all the components on a flat surface. Be careful not to damage the painted finish.

Check that you have all the correct parts.

Remove all packaging materials and dispose of thoughtfully.





Fit the handle into the roasting hood.



Fix the handle into place from inside the hood with a washer, then a spring washer, then a wingnut onto each bolt. Tighten firmly.



Fit the roasting hood carefully onto the firebox. Make sure that the hinge arms on the hood align between the flanges on the firebox.



Lock the hood into place by fitting a hinge pin through the firebox flanges and the hood hinge arms on each side. Fix the hinge pin by inserting "R" clip through the end of each pin.



Installation is simple and only requires putting the three cooking grills in place and fitting the right and left hand shelves.



Two shelves are provided and are easily fitted into the corresponding slots located on both sides of the barbecue



Locate the shelf slot and angle the shelf so that it lines up.



Insert the shelf horizontally and push gently until fits into place.



The shelves can be easily fitted vertically for transport or storage. Attach the match holder provided to the cross brace on the left side of the BBQ.



Finally insert the grease tray. Check regularly and replace when necessary. The safety chain is needed for some situations (see pages 10 & 11)





## Gas Safety Checks

***Before assembling your barbeque, you should ensure your barbeque is suited to the type of gas that you are going to use.***

### Universal LPG, Also Known As Propane:

Barbeques suited to Universal LPG should have a red printed label saying “**UNIVERSAL LPG**”.

This is most commonly supplied as a portable 4 kg or 9 kg gas cylinder, which can be refilled or swapped at petrol stations or your place of purchase when empty.

Some homes have twin 45 kg LPG cylinders permanently installed near an outside wall.

These cylinders supply LPG gas to many appliances in the home via copper pipes, and are filled as required by the gas supply company.

### Natural Gas:

Barbeques suited to natural gas should have a black printed label saying “**NATURAL GAS**”.

This is piped to your home in a similar fashion to water, so there are no cylinders to refill.

You will need to contact your local gas company to determine if Natural Gas is available in your area.

## To Change the Gas Type of Your Barbeque

If your barbeque is manufactured to operate from universal LPG (Propane/Butane mix), it can be connected to LPG (Propane) without any alteration. If you wish to connect that barbeque to natural gas, it must be converted beforehand using the appropriate conversion parts available at your nearest Barbeques Galore store.

If your barbeque is manufactured to operate from Natural Gas and you wish to connect to LPG, it must be converted beforehand using the appropriate conversion parts available at your nearest Barbeques Galore store.

Either conversion must be done by a licensed gas fitter or an authorised gas appliance technician. It is extremely dangerous to use the barbeque with the wrong type of gas. Fire or explosion may result. Conduct a leak test before use.

### For Portable LPG Cylinder Use:

- For cart models, do not attempt to connect to a gas cylinder before the BBQ is secured properly into its cart.
- Ensure that the model you have is labelled “**UNIVERSAL LPG**” and therefore designed to run from an LPG cylinder.
- Check that all the control knobs are in the **OFF** position before any attempt is made to connect the regulator to the gas cylinder.



- Double check that the gas cylinder valve is securely in the **OFF** position before attempting to connect the regulator to the gas cylinder.
- If using without a cart, attach the safety chain provided to the gas cylinder handle and to the cross brace on the right of the barbeque. This is to prevent the hose from being able to be over stretched.
- For cart models hook the LPG cylinder onto the right side of the cart, so that it hangs vertically.
- Look at the hose and regulator that came already assembled to the barbeque. Check that it has a rubber 'O' ring seal on the regulator end of it, and connect this end of the hose to the gas cylinder. You won't need a spanner here. Just turn the fitting in an **anticlockwise** direction and hand tighten as much as you can. This should seal it sufficiently.
- The regulator should be firmly tightened to the cylinder but care must be taken not to over-tighten the connections. The regulator as supplied is the correct regulator for this item.

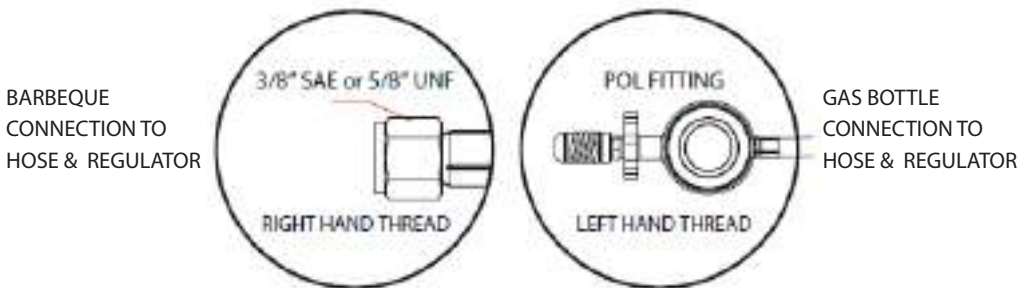

- Ensure the gas cylinder remains upright at all times.
- Should there be any concern in making the correct hose and regulator connection please contact after sales support help line mentioned at the back of this manual.

## For Permanently Installed LPG Supply or Natural Gas Use:

Barbeques which are connected to twin 45 kg LPG cylinders or to Natural Gas must be installed by a licensed gasfitter, in accordance with the requirements of AS 5601, and local gas authority requirements.

There are two approaches to installation:

**Permanent Piped Connection:** Your barbeque may be permanently connected to the main gas lines or LPG cylinders via copper pipe. This must be done entirely by the gasfitter, in accordance with requirements of AS 5601, and local gas authority requirements. Your gasfitter will ensure that your barbeque is permanently connected to the supply via copper pipe, the gas pressure in the lines is adequate, pipe sizes are correct, all connections are





secure, and that all necessary components (such as secondary regulators and manual shut offs) are included where regulations require them. Once this is done, the barbeque cannot be moved. It is a permanent fixture of the property.

**Bayonet Point:** Alternatively, you can have the gas fitter terminate the gas line using a “bayonet point”. This allows you to connect and disconnect the barbeque using a special hose and bayonet termination. Such a hose is provided in the Natural Gas manufactured versions of this barbeque. For LPG installations, an appropriate hose is available from most barbeque retailers, this hose must be fitted to the BBQ and leak tested before use.

Even if your barbeque area already has a bayonet point, you will still need to call upon a gas fitter to ensure gas pressure is sufficient for your barbeque, and to ensure your barbeque functions correctly before leaving. Where a gas fitter is required, the gasfitter must test the safety and operation of the appliance before leaving, including gas pressure, ignition and burner operation.

Conduct a leak test before use.

- For cart models do not attempt to connect to the gas supply before the BBQ is secured properly into its cart.
- If connecting to a Natural Gas supply, ensure that the model you have is labelled “**NATURAL GAS**” and therefore designed to run from Natural Gas.
- If connecting to an LPG supply, ensure that the model you have is labelled “**UNIVERSAL LPG**” and therefore is designed to run from LPG.
- Check that all the control knobs are in the **OFF** position before any attempt is made to connect the hose to the gas supply.
- Attach the safety chain provided to a strong point at the bayonet connection point and to the cross brace on the right of the barbeque. This is to prevent the hose from being able to be over-stretched.
- If connecting to a Natural Gas supply use the hose that is pre-assembled with the barbeque and connect the bayonet to the bayonet outlet.
- If connecting to an LPG supply, use the separately supplied LPG bayonet hose that has been fitted and leak tested and connect the bayonet to the bayonet outlet.
- Should there be any concern in making the correct connection, please contact your local Barbeques Galore store.

**To the installer:** You must instruct the consumer on safe operation, and ensure these instructions are left with the consumer before leaving the site.





## Leak Testing

**Naked flames (matches or other open flames) must not be used to check for leaks. This is a dangerous practice which must be avoided.**

### IF YOU SMELL GAS!

- Immediately isolate the gas supply by turning the gas off at the bottle.
- Extinguish all naked flames.
- Do not operate any electrical devices close to the barbeque.
- Check for leaks as described below.
- Ensure that local area is well ventilated to remove any excess gas.
- If the gas smell continues the barbeque should not be operated under any circumstances and it is important to immediately turn off gas supply and contact the after sales support provider.

***Before proceeding, it is important that you leak test the barbeque. Make sure all the barbeque control knobs are OFF.***

#### **Leak Tests Must be Carried Out in a Well Ventilated Area!**

If you have a portable gas cylinder, turn the cylinder ON by rotating the knob anti-clockwise. If you have a wall connection, ensure the bayonet fitting is connected and supply valve open. Spray or pour soapy water (about the same concentration as washing up water) along the gas line including:

- The gas connection at the inlet of the barbeque, hose connections and regulator connections.
- The gas hose or copper piping, including any joints, valve connections or bends in the piping, and the gas connection at the gas cylinder or the wall connection.
- If bubbles appear, there is a gas leak. **Shut down the gas supply.**
- If the leak is at a connection, check and retighten all gas connections and joints and retest. If the leak is anywhere else, or if you cannot resolve the leak, do not proceed. Immediately turn the gas supply off at the source and contact your local Barbeques Galore store. If you have a bayonet connection, close the supply valve, remove the hose from the wall fitting and contact your local Barbeques Galore store.

***You can also check for leaks using a gas safety gauge, available at your Barbeques Galore store. This provides an easier and more convenient way to check for leaks.***

- After performing the soapy water test, please ensure the fittings are rinsed thoroughly with clean water.

***It is Recommended that a Leak Test be Carried Out on an Annual Basis.  
Check Cylinder Connection Every Time you Refill or Exchange Cylinders.***





## Lighting your Barbeque

**Before using the barbeque please ensure that you have fully read and understood the *IMPORTANT HEALTH & SAFETY INFORMATION* section of this manual.**

### **STARTING THE BARBEQUE:**

***Lighting the barbeque is easy, but must be done with due care.***

- Make sure that the gas is turned on at the cylinder, or supply valve to the barbeque.
- Ensure that the hood is fully open.
- Ensure that all the controls are in the **OFF** position prior to initiating the start up process.
- Make sure there are no obstructions of airflow to the gas unit. Spiders and insects can nest within and clog the burner/venture tube at the orifice. A clogged burner tube can lead to a fire beneath the appliance.

***Flame Thrower Ignition:*** This ignition system works by throwing a flame to the side of the burner to light it. Push any control in and turn anticlockwise to the **HIGH** position. Hold the control knob in until that burner ignites. You may need to push and turn the knob a few times before ignition, as it may take around 5 seconds of flow for the gas to reach the burner.

***Manual Ignition:*** You can light your barbeque manually by using the match holder provided to hold a lighted match next to one of the burners, then turning that burner control knob to **HIGH**. You can access the burner through the cooking grills.

If the burner doesn't light first go, return the control knob to the **OFF** position and try a couple more times. If the burner still does not light, wait a few minutes to allow the gas to disperse before trying again. If satisfactory operation cannot be achieved check the troubleshooting guide on page 25. Otherwise, consult your retailer before proceeding.

***Note carefully: Failure to follow the lighting procedures correctly can lead to a hazardous condition.***



## Checking the Flames

The control knobs have three basic positions: **OFF**, **HIGH** and **LOW**. You can achieve any flame height between **LOW** and **HIGH** by rotating the barbeque control knob between these positions.

## Controlling the Flames

Look into the barbeque so that you can see the flames. They should be a soft blue colour with yellow tips. Check with your retailer if in any doubt about the flames. Special note: "Blowback" is a situation where the flame burns inside the burner, towards the front. It can be recognised by a sharp roaring sound coming from the burner. It is not dangerous unless it is allowed to persist. If this occurs, simply turn the burner **OFF**, wait a few seconds, then relight.

## Turning Off (Shut Down)

When you've finished cooking, leave the burner controls on high for a maximum of 5 minutes to burn off excess grease from the burner and other surfaces. To turn the barbeque off, it is best to turn **OFF** at the supply valve first, and allow all the gas left in the hose to burn off. This will only take a couple of seconds. Then turn all burner controls clockwise to **OFF**.

***Note that failure to follow these shutdown procedures correctly can lead to a hazardous condition.***

It's recommended for good hygiene and safety to empty and clean the fat tray at the end of each cooking session.



## First Time Use

### Preparing To Cook

- Wash the grills (and any optional baking dish or hotplates) thoroughly in warm soapy water before first use. Dry thoroughly and then coat the top surface to prevent food sticking with canola oil or Nice & Easy which is salt free and available from your local Barbeques Galore store. Light the barbeque as described earlier and leave all burners on **HIGH** for about 3 minutes to warm the barbeque up. Once the barbeque is warmed up, you should set the burners to your desired cooking temperature. **NEVER** let the temperature on the hood thermometer exceed 250°C with the hood closed. You're now ready to start cooking up a feast. For ongoing protection of the cooking surfaces, follow the procedures in the Maintenance and Storing sections.
- A good tip is to maintain a layer of Fatsoak (available from your local Barbeques Galore store), in the fat tray. This keeps your barbeque clean and safer.

## Cooking Hints

### Controlling Flare Up

Flare-ups are caused by juices and oils from the food igniting in sudden bursts of flame that come up over the grill. A little bit of flare up as well as the resulting smoke is a good thing. It's what gives barbequed food that unique outdoor flavour. But if it happens too often, or if the flame lasts more than a couple of seconds, your food will char, so you need to control it:

- First of all, cooking very fatty foods may cause a lot of flare up. You should trim excess fat off your meat.
- Excess flaring usually means the burners controls are up too high, turning them down before flare-up occurs will usually prevent it happening in the first place.
- Moving the meat away from the flare up will also reduce the problem.
- Some very fatty foods are best cooked on the optional hotplates or indirectly with the hood closed. Never add more hotplates to the barbeque than the optional centre hotplate or baking dish and one additional optional side hotplate. At least one section of grill or empty space is necessary for ventilation and to prevent overheating. Always remember to switch the barbeque **OFF** once you are finished cooking.



## Keeping Your Food Moist

***It's easy to keep your food moist and succulent on a barbeque by following these guidelines:***

- Use tongs instead of a fork when turning meat and poultry. A fork pierces the flesh and causes the juice to seep out.
- Resist the temptation to keep turning meat over. Juices tend to rise to the top of a piece of meat and then settle. Each time you turn the meat over, the surface juices are lost. It's usually better to quickly sear the meat on each side (about half a minute) then leave the meat to cook on one side at a time, turning once only before serving.
- Baste food with light marinade or oil a couple of times while cooking, though watch out for excessive flare-up if too much oil is used.
- Using the roasting hood as outlined later in these instructions is an excellent way to preserve moisture and succulence and takes most of the hard work out of barbeque cooking.

## Other Useful Tips

***You don't need to be an expert to serve up a tasty, good looking meal. Try these ideas:***

- Although cooking on the optional hotplate seems easier, cooking on the grill gives you a more authentic barbeque flavour. Natural juices vapourise, with the vapours penetrating back into the food.
- As an alternative to simply grilling, try marinating your meat, fish, poultry or vegetables first. The longer you leave the food to stand in the marinade, the more thoroughly the flavour will soak through. Several pre-made marinades are available and good recipes are easy to come by. It is safe practise to leave food marinating in the refrigerator.
- If you use a tomato or sugar based sauce for basting, apply it in the last 5-10 minutes of cooking. Using these sauces over a longer period of time will result in over-browning.
- To prevent meat from curling, slash any fat before cooking at roughly 5cm intervals, taking care not to cut into the meat.
- Avoid burning or charring food as this has been shown to be unhealthy. Don't leave cooked food standing for too long before eating.





## Covered Cooking

### Cooking with the Hood Closed

Using the roasting hood traps heat, moisture and flavour that is normally lost on an open top barbeque. The Ziegler and Brown Triple Grill is designed with plenty of power to heat up quickly and cook lots of food with the hood either open or closed. With the hood closed and the barbeque already pre-heated, its important to then turn burners to **LOW** and to **OFF** as required, in order to not overheat the barbeque which could result in increased temperature hazards and burning your food. **NEVER** let the temperature on the thermometer read over 250°C.

For covered cooking, there are two basic ways to cook:

(A) Direct Cooking and (B) Indirect Cooking

### (A) Covered Cooking-Direct Cooking Method

This is when you place the food directly over the lit burners, either on the grills, the optional hotplates, the optional baking dish, the optional pizza stone or the optional warming rack.

This method is great for frying, searing and grilling, especially with thinner cuts and foods that require shorter cooking time. Cooking takes less time than with the hood open, and the results are more tender and juicy. Preheat the barbeque with all burners on **HIGH** and the hood closed for three minutes until the hood thermometer reads around 200°C. Importantly, once the barbeque is pre-heated and the hood is closed, heat is trapped around the food, so the burners will often need to be turned to **LOW** and in many cases, one or more of the burners **OFF**. Heat from the lit burner(s) will circulate all through the hood cooking quite evenly. Very fatty foods like sausages, can be cooked completely above the **OFF** burners, retaining juiciness and flavour without risk of flare-up that results only in burning. Quite close attention needs to be paid to the food, and the burners frequently reset to **LOW** or **OFF** as required to prevent overheating.

Don't be afraid to open the hood often to check progress. You are in full control of the temperature by turning burners higher, lower or **OFF** as required. The gas burners will respond instantly and powerfully to your control. Most importantly, use the hood thermometer as a warning guide that the barbeque is too hot. For grilling most foods, aim to keep the thermometer below around 200°C. **NEVER** let the temperature on the thermometer reach over 250°C or the barbeque may overheat and burn your food. A separate probe thermometer is available as an accessory from all Barbeques Galore stores. This takes the guesswork out of knowing when your food is cooked.

***Always remember to switch the barbeque OFF once you are finished cooking***





## (B) Covered Cooking-Indirect Cooking Method

This is when you place the food either above burners that are **OFF** or shielded from direct heat by using an optional drip pan and roasting rack or any other method of shielding the food from direct heat such as aluminium foil under a roasting rack, or a pizza stone. The other burners are adjusted in combinations of **LOW** and **OFF** to maintain constant lower roasting temperatures. This method is ideal for slow cooking thicker cuts of meat, legs of lamb, pork, shoulders of beef, whole chickens and whole fish.

Moist, hot air rises from the lit burners and circulates around the food, trapping juices and flavour. Even cakes and breads can be cooked in your barbeque this way. Cooking lower and slower lets the food cook completely through without burning on the outside, yet remaining juicy and tender on the inside.

Preheat the barbeque with all burners on **HIGH** and the hood closed for 3 minutes or until the hood thermometer reads around 200°C. Best results are achieved by placing your roast in a rack and that rack in a drip pan or baking dish. The roast is slightly elevated to allow heat to circulate all the way around, and water, wine, juices, herbs can be added to the drip pan to help flavour the roast and make a baste or gravy. Once the barbeque is pre-heated and the hood is closed, heat is trapped around the food, so the burners that are on will mostly only need to be on **LOW** and in many cases, one or two of the burners turned **OFF**. Heat from the lit burner(s) will circulate all through the hood cooking quite evenly.

Position the food on the grill over the **OFF** burners or for larger roasts, use a large drip pan or baking dish positioned centrally in the barbeque.

Importantly, use the hood thermometer as a warning guide that the barbeque is too hot. For roasting most foods, aim to keep the thermometer below 200°C to avoid burning.

For short periods of browning only, or for 10 minutes to make pork crackling, aim for around 240°C.

For smokey roasting, lower temperatures and longer cooking times will result in more intense smoke flavour and more tender meats. Aim for under 150°C.

Always use a probe thermometer to ensure that the meat has cooked all the way through to the right temperature. **NEVER** let the temperature exceed 250°C on the hood thermometer or the barbeque may overheat and burn your food. A separate probe thermometer is available as an accessory from all Barbeques Galore stores. This takes the guesswork out of knowing when your food is cooked.

***Always remember to switch the barbeque OFF once you are finished cooking***





## Barbeque Tip

Great chefs will tell you that most meats need to “rest” away from the heat of the barbeque before slicing for several minutes to allow the moisture pushed to the surface to redistribute. If you don’t rest the meat, moisture that has pooled near the surface will run out and the rest of the meat will be quite dry. Covering the meat in aluminium foil while its resting helps keep it from cooling too fast.

Use the few minutes while resting the meat to open the barbeque hood, turn all burners to **HIGH** for 3 or 5 minutes to burn off food residue. After 5 minutes, turn the barbeque **OFF**. While the cooking surfaces are still hot, take a long handled brush or scraper and remove remaining oil and food residue. You should use an oven mitt to avoid burns. 5 minutes now will save 30 minutes next barbeque.

***Always remember to switch the barbeque OFF once you are finished cooking.***

## Optional Cookware Accessories designed specifically for Triple Grill

### Large Hotplate

This reversible hotplate is available to replace the centre grill. The optional cart has integral storage for the unused grill or hotplate. Great for direct cooking eggs, pancakes, onions or very high fat foods to completely avoid flare. Use griddle side up as a more fat free option. Maximum hotplate coverage in this barbeque is one large plus one small hotplate.

### Small Hotplate

This small reversible hotplate/griddle is available to replace either side grill. The optional cart has integral storage for the unused grill or hotplate. Great for cooking eggs, pancakes, onions or very high fat foods to completely avoid flare. Use griddle side up as a more fat free option. Maximum hotplate coverage in this barbeque is one large plus one small hotplate.

### Baking Dish

Use to replace the centre grill. Use with the included rack for roasts, or without the centre rack for baking. Great for shallow frying or as a food warmer. The rack doubles as a pot stand to help protect your table.

### Trivet

Use to replace the centre grill. When “Wok” side up it holds the optional wok centre close to the burner for maximum heat. Great for stir fries, steaming or any wok based cooking. When “Pan” side up it lifts the support ring slightly above the cooking surface to minimise heat transfer. Great to support the optional pizza stone for pizza, breads or stone cooking. You can cook indirectly with the burner beneath **OFF** and the hood closed, and you can still open the hood and add a burst of direct heat from the centre burner to crisp up your pizza base or warm up your garlic bread. Use the included mini trivet for smaller pots.



## Warming Rack

Significantly increases cooking capacity while still giving great access to the primary cooking surface. Use with hood open to keep food warm or slow roast with the hood closed. You can roast really fatty food like sausages or the warming rack with almost no attention. The more gentle heat roasts slowly so very little moisture is expelled. You will be amazed how plump and juicy the humble snag turns out this way.

***Check in store for the full range of Ziegler & Brown accessories.***

## Internal Meat Temperatures

### Beef

***Meat Probe temperature:***

Rare 140°F / 60°C. Medium 150°F / 66°C. Well-done 170°F / 77°C

### Lamb

***Meat Probe temperatures:***

Rare 140°F / 60°C. Medium 150°F / 65°C. Well-done 165°F / 75°C

### Veal

***Meat Probe temperatures:***

Rare not advised. Medium 155°F / 70°C minimum safe temperature. Well-done 165°F / 75°C

### Pork

***Meat Probe temperatures:***

Rare not advised. Medium 150°F / 65°C minimum safe temperature. Well-done 160°F / 70°C

### Poultry

***Meat Probe temperatures:***

Rare not advised. Medium 170-175°F / 75-80°C minimum safe temperature.

Well Done not advised; poultry tends to dry out over 175°F / 80°C

***To obtain correct temperature use an instant-read meat thermometer in the thickest part of the flesh, careful not to touch any bone.***



## Cooking Times

### Poultry

<b>Cut of Meat</b>	<b>Weight or Thickness</b>	<b>BBQ Method</b>	<b>Approx Cook Time</b>
Chicken (whole)	2 kg	Indirect	70-80 min
Chicken (halved or quartered)	2 kg total	Indirect	55-65 min
Chicken (breasts, boneless)	150 g ea	Direct	12-15 min
Chicken (breasts, boneless)	150 g ea	Indirect	23-25 min
Wings	120 g	Direct	23-30 min
Wings	120 g	Indirect	35-40min
Cut Up Legs and Wings	2 kg	Direct	10 min
Cut Up Legs and Wings	2 kg	Indirect	40 min
Boneless Cubes (For Kebabs)	2.5 cm	Direct	12-15 min total
Turkey (Whole)	4.5 kg	Indirect	2-3 hours

### Beef

<b>Cut of Meat</b>	<b>Weight or Thickness</b>	<b>BBQ Method</b>	<b>Approx Cook Time</b>
Roasts	2 kg	Indirect	50 min per kg (rare)
Steaks (T-bone, New York, Porterhouse, Round, Sirloin)	2.5 cm	Direct	5-6 min per side (rare)
Rump Steak	3.5 cm	Direct	5-7 min per side (med rare)
Minute Steaks	0.5 cm	Direct	1.5-2 min per side (rare)
Ground Beef Patties	2.5 cm	Direct	4-5 min per side (rare)
Ground Beef Patties	2.5 cm	Direct	5-6 min per side (med. rare)
Ground Beef Patties	2.5 cm	Direct	6-7 min per side (well done)

Thermometer Temperature: Rare = 60°C, Medium = 66°C, Well-done = 77°C

### Seafood

<b>Cut of Meat</b>	<b>Weight or Thickness</b>	<b>BBQ Method</b>	<b>Approx Cook Time</b>
Whole Fish (with or without head and tail)	2 kg	Indirect	30-35 min total
Steaks & Fillets	2 cm	Direct	3-4 min per side
Prawns	Medium sized	Direct	1.5-2 min per side
Lobster Tails	300 g	Direct	9-13 min

Fish is done when flakes easily when prodded with a fork or knife in the thickest part. Frozen fillets should not be thawed before cooking. Cooking times will be approximately double that of fresh fish.





## Maintenance – Cleaning Your Barbeque

***Your barbeque will look better and last longer if you keep it clean. Follow these simple steps:***

- Throwing cold water over any hot surface of the barbeque is NOT recommended and is potentially dangerous.
- Avoid handling and touching hot parts of the barbeque.

### ***The Cooking Surface:***

Once cooking is finished a burn-off process to clean the barbeque should be as follows:

- Remove all excess burnt food with a long handled scraper or brush.
- Light both burners, set to the **HIGH** position and leave running with the hood fully open for approximately 5 minutes.
- During this 5 minute period most excess food, fat and juices should be burnt off making cleaning easier.
- The roasting hood must be left in the open position during the burn off period.
- When done turn the barbeque **OFF** at the control knobs and at the gas supply valve.
- Once the barbeque has cooled, using Bar-B-Chef Heavy Duty Cleaner and warm water, scrub the cooking surfaces with a long handled brush or scourer. Rinse thoroughly with fresh warm water.
- Once dry, store barbeque with the hood closed and out of the elements and direct sunlight.

### ***The Burners:***

- Occasionally the burner holes may get slightly clogged with grease and food particles. Leaving the burners on **HIGH** for a maximum of 5 minutes with the hood open after you've finished cooking will remove most of this.
- Check the burners periodically for more persistent blockages. In particular, you should ensure that the aeration vents are free of insect nests and spider webs.
- To clean the burners, once **OFF**, let them cool down and inspect them. If any of the holes are clogged, use a toothpick to unclog the holes.

### ***The Barbeque Firebox and Hood:***

- Regular care and maintenance of the barbeque firebox and hood will significantly increase its life and long term appearance.
- Excess grease and fat can be removed using Bar-B-Chef Heavy Duty BBQ Cleaner and warm water with a soft scraper (not metal edged). Do not use caustic cleaning agents as these can quickly damage surface coatings and gradually damage even metal finishes.
- Before cleaning the inside of the body it is advisable to let the barbeque fully cool, then remove the cooking surfaces and be careful not to get water into the burner holes.
- Care must be taken not to immerse the gas controls (manifold and injectors) in water.
- After cleaning and re-assembling the barbeque it is important to check that the barbeque functions correctly.





### ***The Drip Tray.***

- You should change the fat absorbent material regularly and keep the fat tray itself clean to prevent a build up of grease. If you don't do this, a fat fire can result. This can be quite dangerous, and will certainly void the warranty on your barbeque.
- A good tip is to line the bottom of the fat tray with a layer of Fatsoak (available from your local Barbeques Galore store).

### ***Other Surfaces:***

- Once the barbeque has cooled, wipe down as required with warm soapy water.

## Storing your Barbeque

Your barbeque is designed to be used outdoors. However, just like a car, you will prolong the life of the appliance if you store it out of direct exposure to the elements when not in use. Ideally:

- Place a waterproof cover over it. These are available from all Barbeques Galore stores. (Tip: Place a sponge between the barbeque and the cover to promote ventilation and minimise condensation)
- Where possible, move the barbeque to a covered location. If you are storing it in a closed room (e.g. a shed or a garage) you should keep the cylinder away from any other cylinders or any cars, boats, motorcycles or any other petrol engines.
- If you don't intend to use it for a few months, lightly spray all surfaces with canola oil. This will help protect the surface from deterioration.

## Servicing your Barbeque

Apart from cleaning, your barbeque is a fairly low maintenance item. A couple of things are worth looking at though. Remember to turn **OFF**, cool the barbeque down and disconnect the gas before any maintenance is carried out.

- If there are any signs of wear or cracking in the barbeque hose, you will need to replace it immediately. Ensure you replace it with a hose and regulator purchased from Barbeques Galore to ensure proper gas connection compatibility. Connect the nut of the hose to the gas inlet on the right side of the barbeque. You **MUST** use a spanner to tighten it properly. Do not use sealing tape. The connection is designed to seal properly without it. Perform a leak test as explained in the installation section before using.
- If your barbeque uses a flexible hose to connect to the gas, check the rubber O-ring on the regulator end of the hose assembly at least once a year. If it appears worn or cracked, have it replaced. Always check that the 'O' ring is in place when connecting or disconnecting from the gas cylinder.
- We recommend having your barbeque checked by an authorised service agent every 5 years. This is to ensure there are no leaks and that all components are still functioning correctly.





- If you use a portable LPG gas cylinder, you will need to have the cylinder serviced or replaced every ten years. The date of the last service should be stamped on the neck of the bottle.
- Occasionally you will need to remove the burner assembly for cleaning or adjustment. To remove the burner, first turn the control knobs OFF and disconnect from the gas supply. Once the barbeque has cooled down, remove the burner assembly by lifting it upwards until it disengages from the locking spring clips. Once it is unlocked from the spring clips lift the burner upwards and backwards away from the valves at the front of the bbq. Reverse this procedure to reinstall the burner assembly, making sure that the burner openings are each fitted properly over the gas valves and that the locking spring clips have fully engaged.

As you can see, it's easy to keep your barbeque in great shape so it can give you years of trouble free enjoyment.







## TROUBLE SHOOTING

<b>Problem</b>	<b>Possible Cause</b>	<b>Prevention / Cure</b>
Burner will not light	No gas flow Obstruction of gas flow  Burner is off the valve Spider webs in venturi Burner ports blocked	Check cylinder contents and refill Clear burner tubes Check for bent or kinked hose Re-engage burner onto the valve. Clean venturi Clean burner ports
Sudden drop in gas flow or reduced flame height	Cylinder out of gas.	Check cylinder contents and refill
Irregular flame pattern, flame does not run the full length of burner	Burner ports are blocked	Clean burner ports
Flame yellow or orange	Burner may have residue Spider webs in venturi Food residue or grease on burner Burner is off the valve Salt in food / marinade	Burn on <b>HIGH</b> for 5 minutes with lid open. Clean venturi Clean burner  Re-engage burner onto the valve No need to be concerned
Flame blow out in high or gusting winds	Turn front of BBQ to face wind Low on gas	Turn front of BBQ into the wind. Check cylinder contents and refill
Flare-up	Grease build up Excessive fat in meat High cooking temperature	Clean grill Trim fat from meat before grilling Lower temperature accordingly
Persistent grease fire	Grease trapped by food build-up around burner system	Do not apply water. Turn knobs to <b>OFF</b> . Turn gas <b>OFF</b> at cylinder. Leave lid in closed position and let fire burn out. After grill cools, remove and clean all parts
Persistent flashback (fire is burning tubes)	Burner and/or burner tubes are blocked.	Turn knobs to <b>OFF</b> . Clean burner and/or burner tube(s). Relight
Inside of lid is peeling - like paint peeling	Baked on grease build up has turned to carbon and is flaking.	Clean thoroughly





# Recipes

Anything you can cook in your oven you can do on a barbeque: roasts, breads, casseroles, pizzas, lasagne, are just a few of the possibilities. Here are some simple recipes to get you started.

## Emperor's Big Breakfast

*Serves 6*

*Cooking Time 10 - 15 minutes*

Accessories:

Triple grill reversible centrehotplate

Triple grill reversible side hotplate

Triple grill warming rack



### Ingredients

- 6 eggs
- 12 slices of bacon
- 4 to 4 large mushrooms
- 8 breakfast sausages
- 4 tomatoes, halved
- Oil
- Salt and pepper

### Preparation

1. Remove the centre and 1 side grill and replace with triple large grill hotplate and side hotplate, smooth side up. Preheat your barbeque using all burners on **HIGH**, hood closed until the temperature reaches 200°C. Open the hood turn all burners down to **LOW**. Adjust burners while cooking to just maintain a sizzle.
2. Place the bacon on the hotplate and the sausages on the grill, keep turning as required.
3. After 6 minutes place the tomatoes and mushrooms on the grill for a further 4 minutes.
4. After another 4 minutes turn the tomatoes and mushrooms over, lightly oil the hotplate, add the eggs and cook to your liking.

**TIP:** Use the warming rack to keep food warm as it's cooked. You can easily double the barbeque capacity this way by stacking cooked food on the warming rack.

***Always remember to switch the barbeque OFF once you are finished cooking.***



# Mates Steak

## with a Garlic Butter sauce

Serves 10

Cooking Time 10 - 20 minutes



### Ingredients

- 10 rump steaks (1.5 - 2 inch thick)
- Salt
- Cracked pepper
- Olive oil
- 3 cloves garlic - finely chopped
- 250g unsalted butter
- 1 teaspoon Worcestershire sauce
- 2 tablespoons chopped parsley

### Preparation

1. Preheat barbeque, all burners on **HIGH**, hood closed until temperature reaches 240°C.
2. Oil both sides of the steaks with and sprinkle salt and pepper on one side.
3. Place the steaks spiced side down onto the open grill for 3 to 4 minutes. Cook with the hood open, all burners on **HIGH**.
4. Salt and pepper the other side of the steaks. Flip steaks over and repeat grilling for 2 to 3 minutes on **HIGH**.
5. Check the steaks by pressing gently with the back of your tongs. Rare steaks will spring back quickly. Medium steaks will spring back slowly. Medium well-done and well-done steaks will not spring back.
6. Once cooked to your liking, cover steaks loosely with foil to rest for 5 minutes.

**TIP:** Usually it's advisable to turn steak only once to minimise lost juices that are driven to the top of the steak by the heat. An alternative method is to turn the steaks every 30 seconds so that the juices never get a chance to reach the surface, It's more work this way but works surprisingly well.

### Garlic Butter Sauce

1. Put the butter in a bowl and leave at room temperature until it is soft enough to work. Add the garlic, Worcestershire sauce, parsley and mix to combine thoroughly. Add salt and pepper to taste.
2. Using a spatula scrap the butter mixture on to a square of plastic wrap. Shape into a log and roll the mixture up in the plastic, twisting the ends.
3. Refrigerate until firm. When ready to use, remove wrap and slice into rounds. Place on hot steak just before serving.

**TIP:** Once rested place the steak back on the grill on **HIGH** for 20 seconds on each side if you like your steak served hot.





# Ziegler Kebabs

Serves 2

Cooking Time 15 - 20 minutes

Accessories:

Ziegler and Brown Flexible Skewers



## Ingredients

- 10 lamb chunks
- Salt and pepper
- Olive oil
- Assortment of vegetables your choice: corn, chillies, capsicum, zucchini, baby squash, mushrooms.

## Preparation

1. Preheat your barbeque using all burners on **HIGH** and the hood closed, to 200°C.
2. Using the Zeigler & Brown Flexible Skewers organise the lamb and vegetables so that the pieces are scattered.
3. Lightly brush with olive oil and season with salt and pepper to taste.
4. Open the hood, turn all burners down to **LOW**, cook the kebabs, turning as required for 15 minutes or until the lamb is cooked to your liking. Adjust burners while cooking to just maintain a sizzle.

***Always remember to switch the barbeque OFF once you are finished cooking.***





# Lemon Dill Snapper

Serves 4

Cooking Time 45 - 55 minutes

Accessories:

Bar-B-Chef Fisharoo



## Ingredients

- 1 whole snapper (scaled and gutted)
- 300ml sour cream
- 1 lemon zested and juiced
- 1 lemon sliced
- ½ bunch fresh dill
- Parsley for presentation
- 1 banana leaf (or you can use aluminium foil)

## Preparation

1. Preheat your barbeque with all burners on **HIGH** and the hood closed to 200°C. Turn both outer burners to **LOW**. Turn centre burner to **OFF**.
2. Combine sour cream, lemon zest, lemon juice and chopped dill into a bowl. Add salt and pepper to taste.
3. Spread the mixture generously inside the fish.
4. Place the banana leaf or foil on the bottom of the Bar-B-Chef Fisharoo and lay the snapper on top. Place the sliced lemon pieces and parsley on top of the fish and close the Bar-B-Chef Fisharoo.
5. Place the Bar-B-Chef Fisharoo centrally in the barbeque, making sure both bottom legs are extended so that the fish is not in direct contact with the grill. The banana leaf or foil shields the fish from direct heat.
6. Adjust burners as necessary to **OFF**, **LOW** or **HIGH** during cooking. It's best to aim about 150°C. Close the hood and cook until you see flaking starting at the thickest part of the fish.
7. Let the fish rest, covered with foil for 10 minutes before serving.

**TIP:** Fish will continue to cook whilst covered and resting. Take the fish out of the BBQ once you see it flaking.





# Roast Beef Rack

*Serves: 6*

*Cooking Time: 60 minutes*

Accessories:

Bar-B-Chef Enamel Enamel Drip Tray

Bar-B-Chef Roast Holder

Bar-B-Chef Remote BBQ Thermometer



## Ingredients

- 3kg or 6 boned beef rib rack
- 1 butternut pumpkin
- 2 jacket potatoes
- 1 sweet potato (yam)
- 3 spring onions
- 1 bunch of rosemary
- 1 bunch of sage
- 1 cup red wine
- 250ml beef stock
- Salt and pepper
- Olive oil

## Preparation

1. Using all burners on **HIGH** and the hood closed, preheat your barbeque to 230°C.
2. Rub the beef with salt and pepper and olive oil. Cover the beef with the picked herbs.
3. Peel and halve the onions, halve the potatoes and cut the pumpkin into small pieces. Pour the beef stock and the red wine into the Bar-B-Chef Enamel Drip Tray.
4. Place the beef on your Bar-B-Chef Roast Holder, position the onions, potatoes and pumpkin around the beef and place into the hot barbeque at about 230°C.
5. Turn both outer burners to **LOW**. Turn centre burner to **OFF**. Adjust burners while cooking if necessary to maintain around 250°C.
6. Insert the Bar-B-Chef barbeque Remote Thermometer and set for beef (medium rare or however you prefer) close the hood and cook for 15 minutes, then turn down to 180°C and cook until the Bar-B-Chef Remote Thermometer tells you the desired temperature is reached.
7. Remove from the barbeque and cover with foil before serving.

***Always remember to switch the barbeque OFF once you are finished cooking.***





# Grilled Salami and Bocconcini Pizza

*Serves 2*

*Cooking Time 15 minutes*

Accessories:

Ziegler and Brown Reversible Trivet

Ziegler & Brown Large Pizza Stone



## Ingredients

- 1 pizza base (home made, pre-made or flat bread)
- 150gms sliced bocconcini cheese
- 100ml tomato pasta sauce or your favourite salsa
- 12 (approx 100gm) medium thick slices of salami of your choice
- 150gm baby tomatoes sliced
- 20 fresh basil leaves

## Preparation

1. Replace the centre grill with the trivet (circle side up) and set the pizza stone in place.
2. Using all burners on **HIGH** and the hood closed, preheat your barbeque to around 200°C.
3. Switch the centre burner off. Grill the salami directly over the side burners for about 1-2 minutes each side until they are just showing grill marks.
4. Spread the base with tomato sauce. Top with grilled salami, tomato and bocconcini. Using 2 side burners on **HIGH**, centre burner **OFF**. Adjust to maintain about 220°C. Cook on the stone with the hood closed for around 15 minutes until the cheese melts.
5. Garnish just before serving with the fresh basil leaves.

***Always remember to switch the barbeque OFF once you are finished cooking.***





# Stir Fry Broccoli and Grilled Chicken

Serves 6

Cooking Time 20 minutes

Accessories:

Ziegler & Brown 30cm wok

Ziegler & Brown reversible trivet



## Ingredients

- 300gms chicken, shred into 25mm strips
- 500gms broccoli cut into florets
- 1 capsicum cut into strips
- 100gms of sliced mushrooms
- 2 tablespoons of soy sauce
- 2 tablespoons olive oil

## Preparation

1. Replace the centre grill with the trivet (circle side down).
2. Using the two outer burners on **HIGH** and the hood closed, preheat your barbeque to around 150°C.
3. Open the hood, switch on the centre burner and start preheating the wok with the olive oil. Dip the chicken strips in the oil and transfer immediately to the side grill.  
Take care as there will be a little flare. Grill 3 to 4 minutes each side.
4. Stir fry the vegetables on **HIGH** for 7 to 10 minutes.  
After 8 minutes, take the chicken from the grill and add straight to the wok. Turn the two side burners to **OFF**. Add the soy sauce, turn to **LOW** and stir thoroughly.

### OPTIONAL SAUCE:

In a saucepan (or the emptied wok) heat on **HIGH** 2 cups of water and 2 chicken stock cubes. Stir until dissolved, then turn to **LOW**. Mix 100mls of water and 4 tablespoons of corn flour until dissolved and add gradually to the sauce, stirring well.

Serve with steamed rice.







# Barbeque Bacon, Onion, Garlic, and Potato Bake

*Serves 6*

*Cooking Time 60 minutes*

Accessories: Ziegler & Brown baking dish



## Ingredients

- 4 large slices of bacon, chopped
- 1.5 kgs peeled potatoes, sliced
- 1 large onion chopped
- 1 clove garlic, chopped
- 300mls thickened cream
- 100mls milk
- 100mls chicken stock
- 1 cup tasty cheese
- 3 tablespoons olive oil

## Preparation

1. Replace the centre grill with the baking dish (put the rack aside, it's not needed). Turn the centre burner to **HIGH** and preheat for 1 to 2 minutes.
2. Add the olive oil, bacon, onions and garlic and saute for a few minutes, turning the heat down if necessary.
3. Turn the burner **OFF**. Let cool a little then add the potatoes, milk, cream and stock. Coarsely stir to spread potatoes and cream.
4. Cover baking dish with foil, turn the side burners **ON**, then to **LOW**. Close the hood and bake for 50 minutes, adjusting burners as required to maintain around 200°C.
5. Once potato is tender, discard the foil, add the cheese on top, close the hood and bake for another 10 to 15 minutes at around 200°C until the cheese has browned.





# RECIPES

---

---

---

---

---

---

---

---

---

---

---

---

---

---

---

---

---

---

---

---

---

---

---

---





# Ziegler & Brown Barbeque Accessories



Other available accessories include:

**Gas Safety Gauge:** Award winning safety device. Shuts gas off fast and completely in case of a major leak, and helps you detect minor ones without worrying about soapy water.

**Weather Cover:** Protect your investment with a cover that fits neatly over your barbeque and protects it from the elements as well as backyard pests.

And there are many more. Ultimately, anything you can cook in the kitchen, you can cook on your barbeque.

G.L.G. Australia Pty Ltd (ACN 001 185 002)

Building A2, Campus Business Park, 350-374 Parramatta Road, Homebush NSW 2140

Ph: 02 9735 4111

## More Information?

Need more information or assistance in any way? You can call your nearest Barbeques Galore store where barbeque experts will be happy to help you. Just phone 1800 978 555 or visit our website at: [www.barbequesgalore.com.au](http://www.barbequesgalore.com.au)

For Warranty information, refer to the enclosed Warranty Card.

## TECHNICAL SPECIFICATIONS

Models – ZG3GC,ZG3GRC,ZG3GLEC

Gas Type – UNIVERSAL LPG

Side Burner Injector Size – 0.75mm each

Side Burner Gas Consumption – 7.5 Mj per burner/hr

Middle Burner Injector size – 0.97mm

Middle Burner Gas Consumption – 12mj/hr

Burner Gas Pressure – 2.75Kpa

Total Gas Consumption – 27mj/hr

Models – ZG3GNGC,ZG3GRNGC,ZG3GLENGC

Gas Type – NATURAL GAS

Side Burner Injector Size – 1.25mm each

Side Burner Gas Consumption – 7.5 Mj per burner/hr

Middle Burner Injector size – 1.6mm

Middle Burner Gas Consumption – 12Mj per/hr

Burner Gas Pressure – 1.0Kpa

Total Gas Consumption – 27mj/hr

IAPMO No GMK 10087



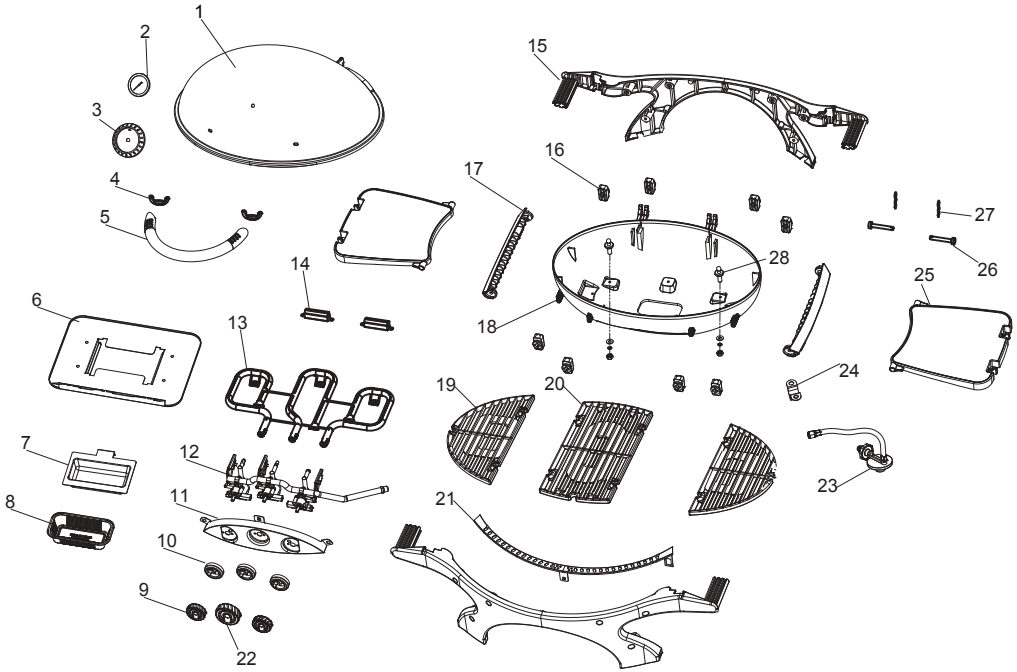

# SPARE PARTS



Key	Part Description	Qty	Code	Key	Part Description	Qty	Code
1	HOOD - CHILLI RED	1	ZG3G030101R	13	BURNER ASSEMBLY	1	ZG3GBURNER
1	HOOD - GUNMETAL GREY	1	ZG3G030101G	14	CROSS FIRE + SCREWS	2	ZG3G030214
1	HOOD - RETRO BLUE	1	ZG3G030101BU	15	FIREBOX SUPPORT CRADLE	2	ZG3G030202
2	THERMOMETER & LOCK NUT	1	ZGTG0105C	16	FIREBOX SPACER	8	ZGTG0214
3	THERMOMETER BEZEL	1	ZG3G030106C	17	CRADLE CROSSBAR	2	ZGTG0216
4	WING NUT	2	ZGTG103	18	FIREBOX	1	ZG3G030201
5	HOOD HANDLE	1	ZG3G030102C	19	SIDE COOKING GRILL	2	ZG3G030206
6	HEATSHIELD (BOTTOM PANEL)	1	ZG3G030210	20	CENTER COOKING GRILL	1	ZG3G030215
7	GREASE TRAY HOLDER	1	ZGTG2013	21	VALVE COVER	1	ZG3GVALCOV
8	FOIL TRAY (PACK OF 5)	1	BCFT5	22	CONTROL KNOB CENTRE LARGE	1	ZG3G021600
9	CONTROL KNOB SMALL	2	ZGTG020300C	23	HOSE & REGULATOR	1	ZGTG0220
10	KNOB BEZEL	3	ZGTG0204	24	REGULATOR BRACKET	1	ZGTG0217
11	CONTROL PANEL - GREY	1	ZG3G030205G	25	SIDE SHELF	1	ZG3G030401
11	CONTROL PANEL - RED	1	ZG3G030205R	26	HOOD HINGE	2	ZGZTGHHS
11	CONTROL PANEL - BLUE	1	ZG3G0205GREY	27	SPLIT PIN	2	
12	MANIFOLD AND VALVE ASSEMBLY	1	ZG3G030211	28	PIN+NUT+WASHER FOR BURNER	2	ZGBURNPIN



Barbeques Galore (Aust) Pty Ltd						
Rating Label						
  <p>AS/NZS 5263.1.7 IAPMO No GMK 10087</p>	Model	-	ZG3GC / ZG3GRC / ZG3GLEC	ZG3GNCG / ZG3GRNGC / ZG3GLENGC		
	Gas Type	-	UNIVERSAL LPG			
	Burner No	-	1 & 3	2		
	Burner Injector Size	-	0.75mm	0.97mm	1.25mm	1.6mm
	Burner Gas Consumption	-	7.5 MJ/hr	12 MJ/hr	7.5 MJ/hr	12 MJ/hr
	Burner Gas Pressure	-	2.75Kpa		1Kpa	
	Total Gas Consumption	-	27 MJ/hr		27 MJ/hr	
	<p>Warning : For Storage and Cylinder Exchange, disconnect hose at the cylinder only, do not disconnect hose from the appliance. Minimum clearances from combustibile surfaces. Side of BBQ - 250mm; Back of BBQ - 250mm; Vertical above BBQ Cooking Surface - 1500mm</p>					

**WARNING:** For Storage and Cylinder exchange, disconnect hose at the cylinder only, do not disconnect hose from the appliance.

Minimum clearance from combustibile surfaces:

Side of BBQ - 250mm

Back of BBQ - 250mm

Vertical above BBQ - 1500mm

## BARBEQUE DIMENSIONS

	WIDTH (mm)	DEPTH (mm)	HEIGHT (mm)
Barbeque only	1004	583.4	481.4
Barbeque and Trolley	1004	794	1120.3

• NOTE: The width increases by 164.4mm per shelf when the shelves are extended fully

Air is admitted from a 139.8mm x 75mm hole underneath the firebox. When the hood is closed, air is also expelled out from the gaps at the back of the barbeque between the hood and the firebox. Please ensure all these gaps remain unobstructed.

**Ziegler  
& Brown**

# TRIPLE GRILL

THE COMPLETE BBQ SYSTEM

