

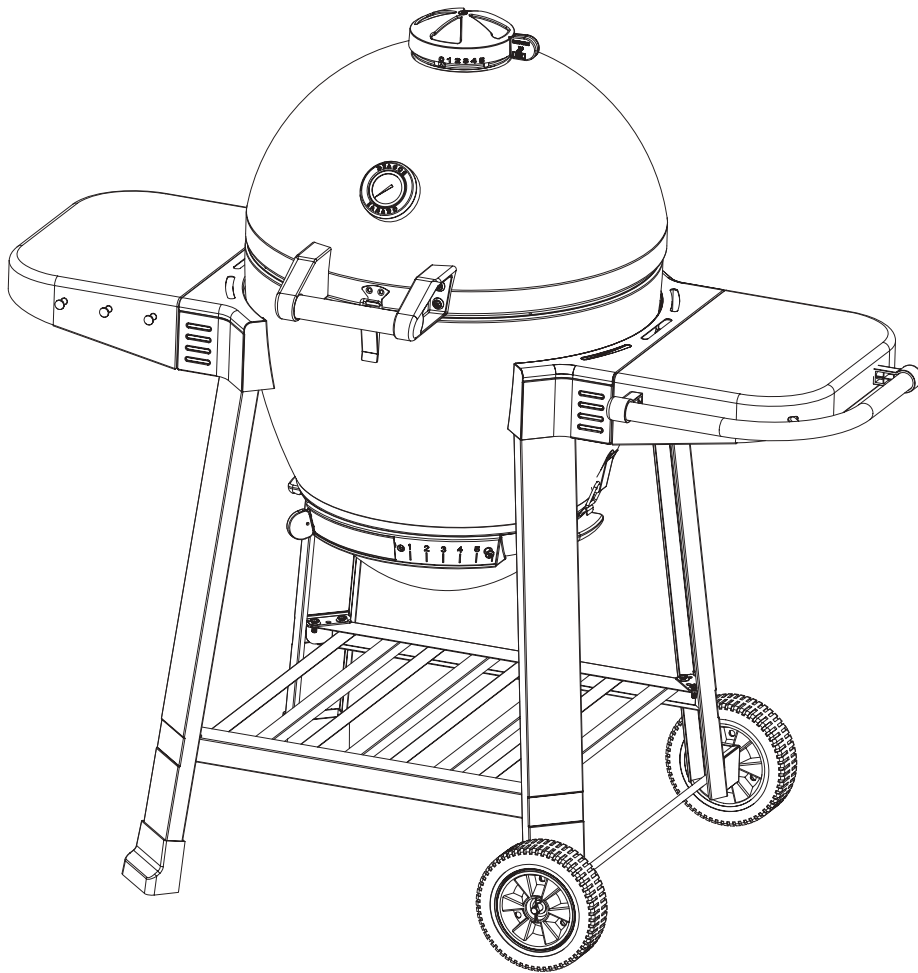

# DRAGON KAMADO

## INSTRUCTION MANUAL

For safe use and enjoyment of your new barbeque



**BARBEQUES  
GALORE**

Model: BC1450J0

Code: PSMKEG

Tools required:

Phillips Head Screwdriver

# **IMPORTANT HEALTH & SAFETY INFORMATION**

## **1. WARNING**

### **FOR OUTDOOR USE ONLY! DO NOT USE INDOORS**

- Please read these instructions carefully prior to assembly and use.
- Failure to follow these instructions could lead to serious injury and/or significant damage to property.
- Do not use the barbecue if there is any doubt over the correct assembly or lighting procedure.
- These instructions should be retained for future reference.
- The barbecue must have a minimum side, back and front clearance from any combustible material of at least 1000mm. Additionally there must be a clearance of at least 2000mm clear above the cooking surface of the barbecue.
- Flammable materials and liquids must be stored well away from the barbecue.
- Aerosols must not be used near the barbecue.
- The barbecue should not be moved when lit or hot.
- A lit barbecue should be attended at all times.
- Avoid dousing the barbecue with water.
- Ensure the barbecue charcoal is completely extinguished when the barbecue is not in use.
- Always allow the barbecue to completely cool down before covering.
- For safety reasons it is advisable to keep a fire extinguisher and fire blanket close to hand.
- Unsupervised children and the infirm should not be allowed close to the barbecue during pre-heat, cooking, burn off or cooling down of the unit.
- Please dispose of all packing materials and carefully and keep plastic bags out of the reach of children.

# SETTING UP THE BARBEQUE

**THIS APPLIANCE SHALL ONLY BE USED IN AN ABOVE GROUND OPEN AIR SITUATION WITH NATURAL VENTILATION, WITHOUT STAGNANT AREAS, WHERE PRODUCTS OF COMBUSTION ARE RAPIDLY DISPERSED BY WIND AND NATURAL CONVECTION**

## FOR OUTDOOR USE ONLY

### 1. POSITIONING

- Please make sure that the barbeque is NOT positioned underneath any combustible material or surface.
- There MUST be a clearance of at least 1000mm from the sides, back and front of the barbeque to any combustible materials or surfaces. There must also be a clearance of at least 2000mm above the cooking surfaces to any combustible surface.
- Flammable materials of any description MUST be kept well away from the barbeque.
- The barbeque must be positioned to avoid walkways, gangways and general pedestrian access.
- The nature of a barbeque is such that many of the surfaces are hot to touch, the positioning of the barbeque should take into consideration the possibility of accidental hand or body contact.

**Any enclosure in which the appliance is used shall comply with one of the following:**

- An enclosure with walls on all sides, but at least one permanent opening at ground level and no overhead cover.  
SEE EXAMPLE 1
- Within a partial enclosure that includes an overhead cover and no more than two walls.  
SEE EXAMPLE 2 & 3
- Within a partial enclosure that includes an overhead cover and more than two walls, the following shall apply-
  - at least 25% of the total wall area is completely open; and
  - at least 30% of the remaining wall area is open and unrestricted  
SEE EXAMPLE 4 & 5
- In the case of balconies, at least 20% of the total of the side, back and front wall areas shall be and remain open and unrestricted

BURNING CHARCOAL INSIDE CAN KILL. IT GIVES OFF CARBON MONOXIDE WHICH HAS NO ODOUR.

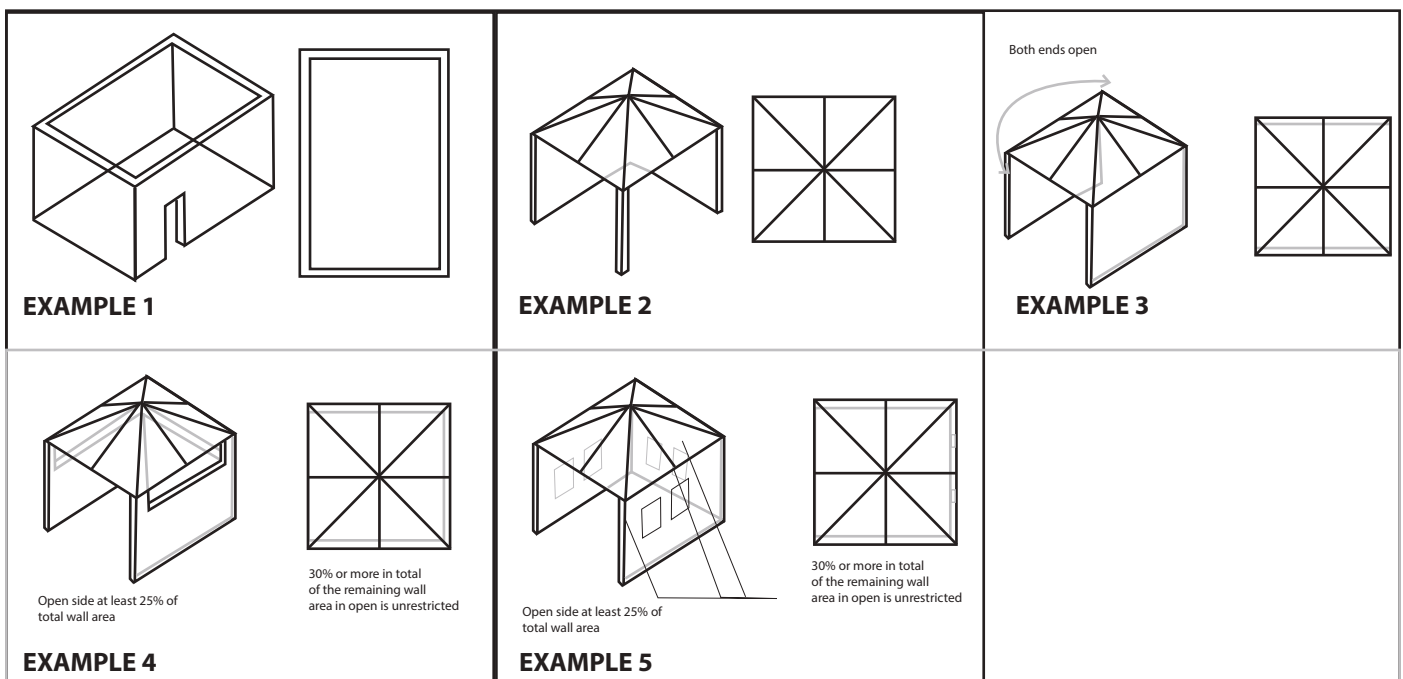

# ASSEMBLY INSTRUCTIONS



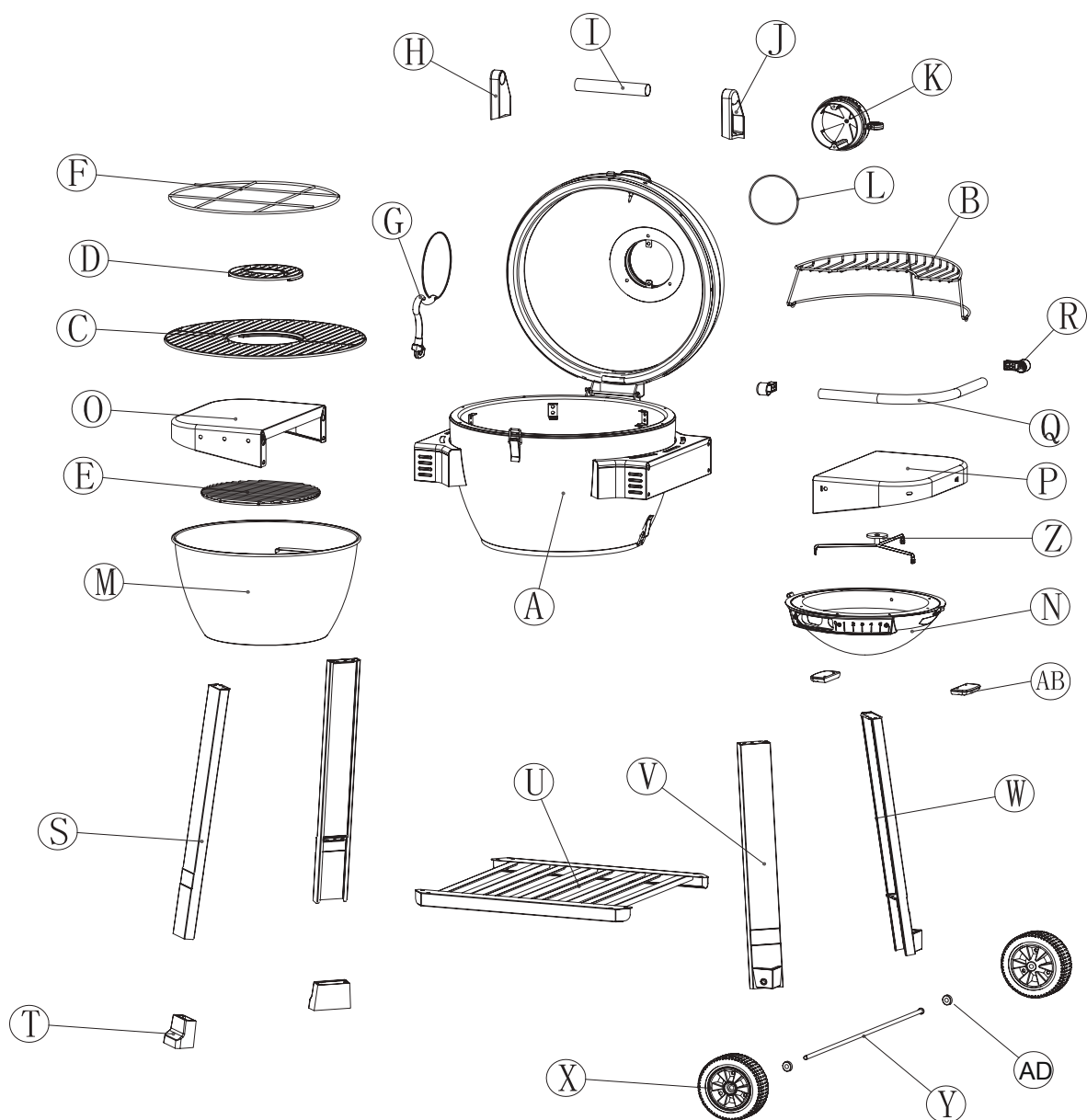



## PARTS LIST

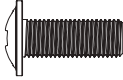
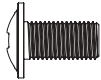

Part	Description	QTY	Part	Description	QTY	Part	Description	QTY
A	Body Assembly	1pc	K	Damper	1pc	U	Bottom Shelf	1pc
B	Warming Rack	1pc	L	Damper O-ring Seal	1pc	V	Right Leg - FRONT	1pc
C	Cooking Grill outer	1pc	M	Fire Bowl	1pc	W	Right Leg - BACK	1pc
D	Cooking Grill inner	1pc	N	Ashpan Assembly	1pc	X	Wheel	2pcs
E	Charcoal Grate	1pc	O	Table - LEFT	1pc	Y	Axle	1pc
F	Trivet	1pc	P	Table - RIGHT	1pc	Z	Ashpan Support	1pc
G	Grill Lifter	1pc	Q	Table Handle	1pc	AB	Ashpan Handle	2pcs
H	Handle Bracket - LEFT	1pc	R	Table Handle Seat	2pcs	AC	Spacer	2pcs
I	Hood Handle	2pcs	S	Left Leg - FRONT & BACK	2pcs			
J	Handle Bracket-RIGHT	1pc	T	Foot	2pcs			

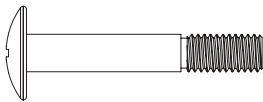
# ASSEMBLY INSTRUCTIONS

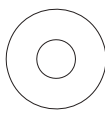
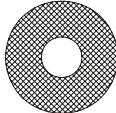
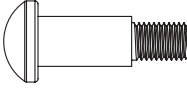
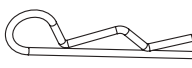
## HARDWARE LIST

AA: 28PCS	BB: 4PCS	CC: 5PCS
		
Bolt (M6x16)	Bolt (M6x12)	Bolt (M4x12)
DD: 1PC	EE: 26PCS	FF: 26PCS
		
Bolt (M6x45)	Spring Washer (ø 6.2)	Flat Washer (ø 16x ø 6.2x1.0)
GG: 2PCS	HH: 3PCS	II: 1PC
		
Fibre Washers	Tool Hook Screw (M6)	Split Pin
KK: 4PCS		
		
Bolt (M5x16)		

# ASSEMBLY INSTRUCTIONS

## Step 1

- a) Fit Foot (T) to each of the Left Legs (S) as shown in the diagram.

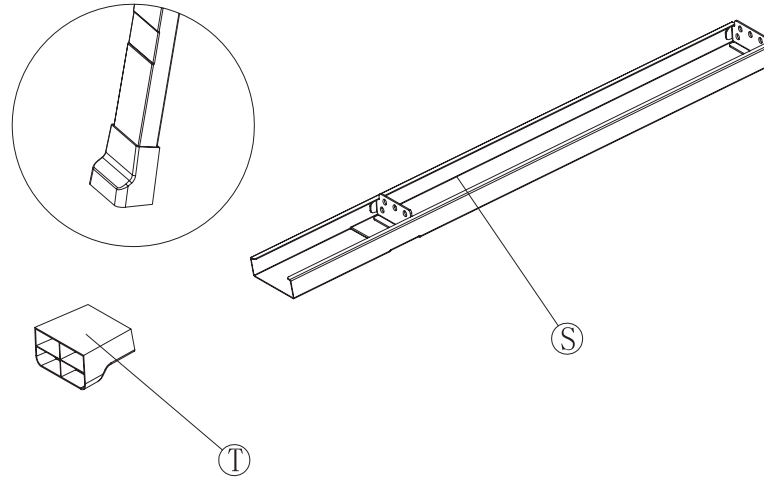

## Step 2

- a) Attach three Tool Hook Screws (HH) onto the Table - LEFT (O) as shown.

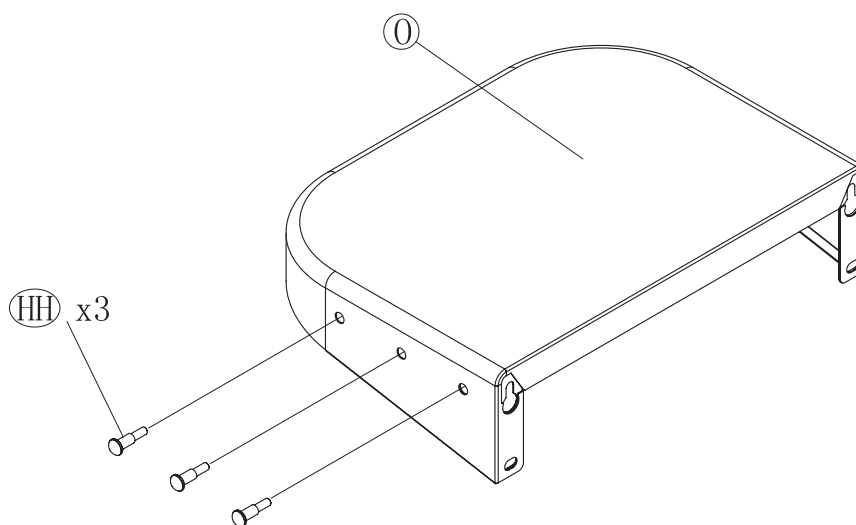

# ASSEMBLY INSTRUCTIONS

## Step 3

- a) Attach the two Table Handle Seats (R) onto each side of the Table Handle (Q).
- b) Secure each with a Bolt (CC).

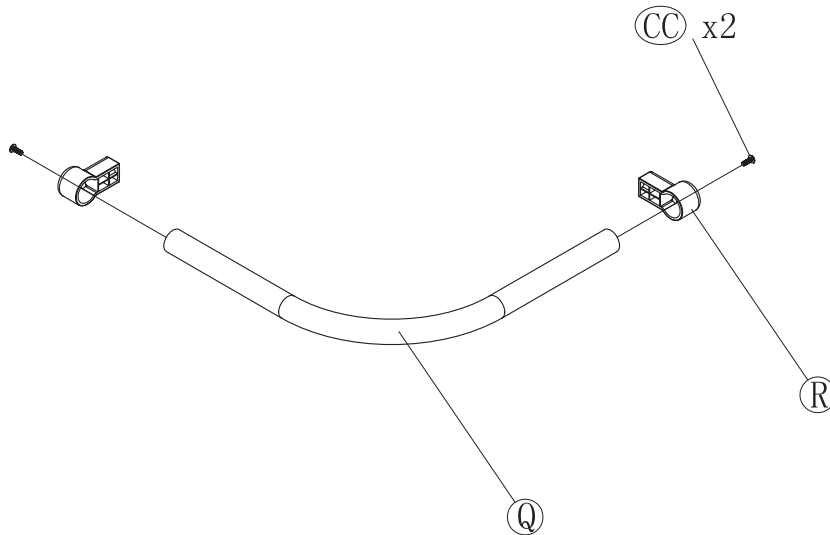

## Step 4

- a) Take the pre-assembled Table Handle (Q) from step 3 and attach it onto Table - RIGHT (P). Secure it with two bolts (BB) and one bolt (DD) as shown below.

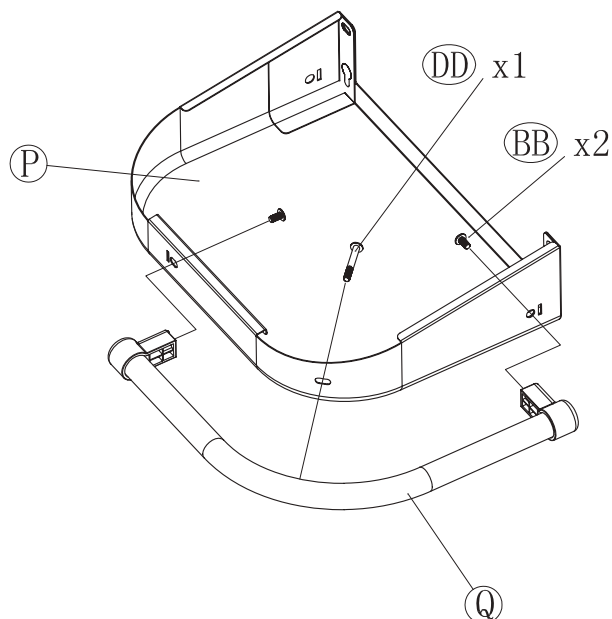

# ASSEMBLY INSTRUCTIONS

## Step 5

- a) Install one Ashpan Handle (AB) onto each side of the Ashpan Assembly (N).
- b) Secure each Ashpan Handle (AB) with two bolts (KK).

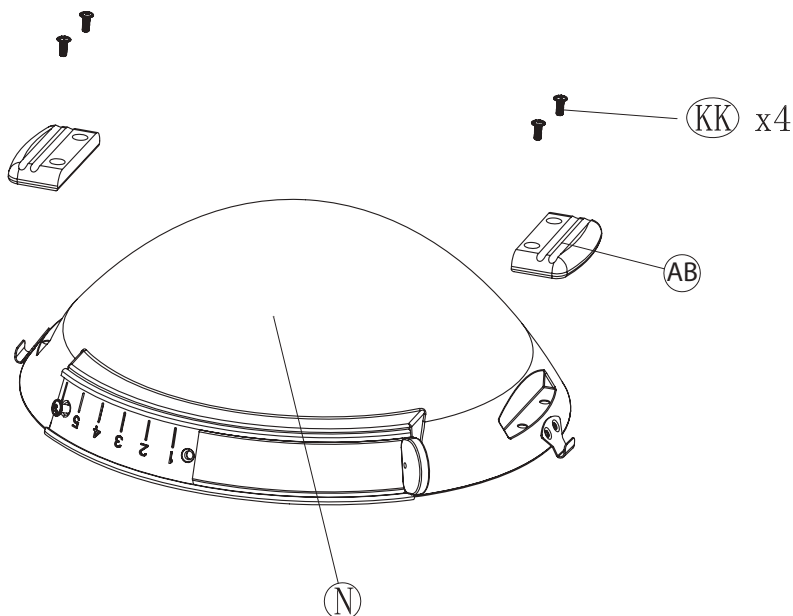

## Step 6

- a) Attach the Ashpan Support (Z) onto the Ashpan Assembly (N) prepared in step 6 and secure it with three bolts (CC).

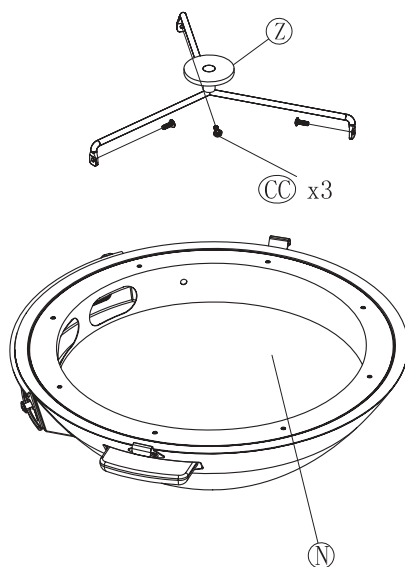



# ASSEMBLY INSTRUCTIONS

## Step 7

- Carefully lay the body assembly down sideways on a firm surface that will not damage the finish.
- Start from the left side of the Body Assembly (A), attach two prepared Left Legs (S) from step 1 onto the left of the Body Assembly (A) each with two Flat Washers (FF), Two Spring Washers (EE) and two bolts (AA).
- Repeat the same procedure on the Right side of the Body Assembly (A) with Right Leg - FRONT (V) and Right Leg - BACK (W).
- Ensure all bolts are properly tightened.

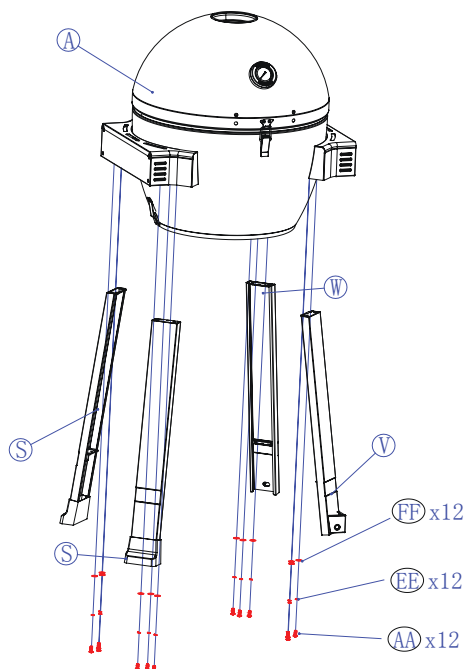

## Step 8

- Stand the assembly upright as shown and attach the Bottom Shelf (U) onto the BBQ legs.
- Secure the Bottom Mesh (U) on each corner with two flat washers (FF), two spring washers (EE) and two bolts (AA).

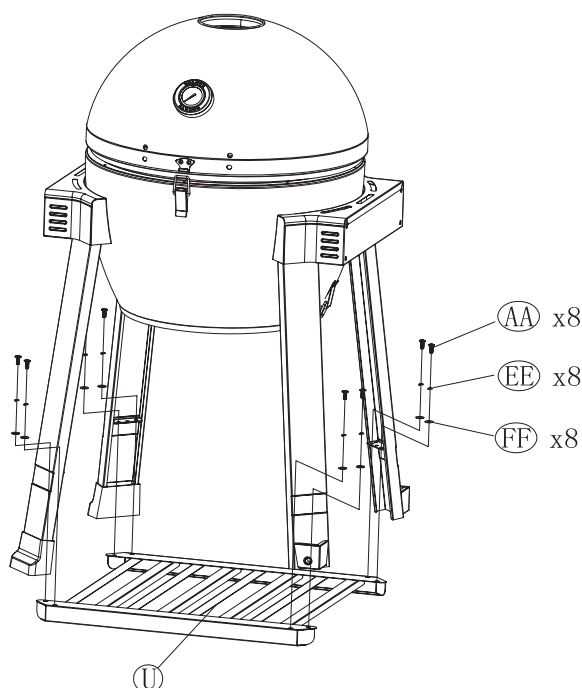

# ASSEMBLY INSTRUCTIONS

## Step 9

- Working on the left side of the leg, lift the BBQ slightly up to fit the Axle (Y) through the wheels (X) and spacer (AD), then through the BBQ legs as shown in the diagram below.
- After attaching both wheels and the axle to the BBQ legs, secure it with the split pin (II) on the end of the axle as shown below.

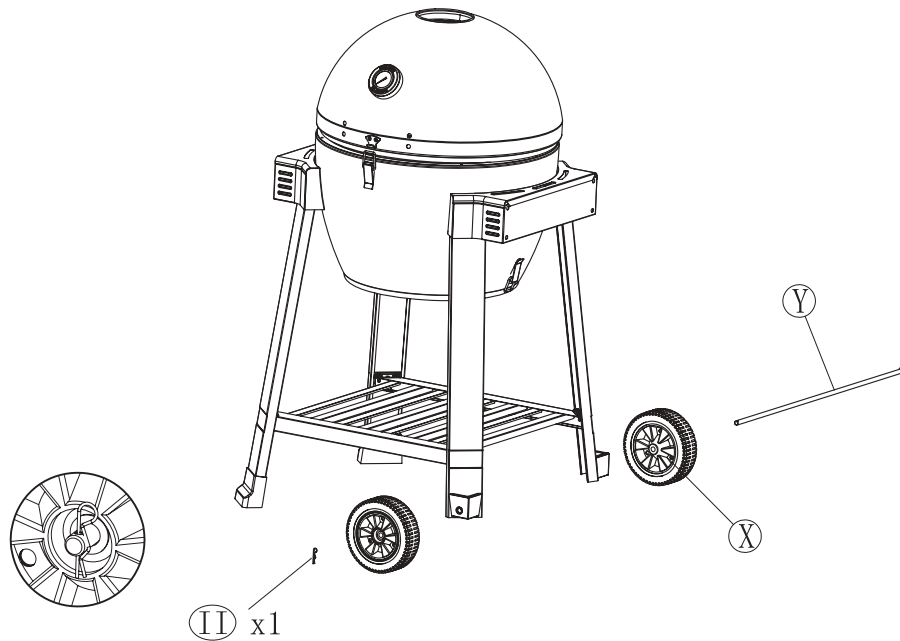

## Step 10

- Align the Hood Handle (I) with Handle Bracket - LEFT (H) and Handle Bracket - RIGHT (J) as shown.
- Secure it to the four pre-drilled holes on the BBQ hood front with two flat washers (FF), two spring washers (EE) and two Bolts (AA) on each handle bracket.
- Ensure all screws are properly tightened.

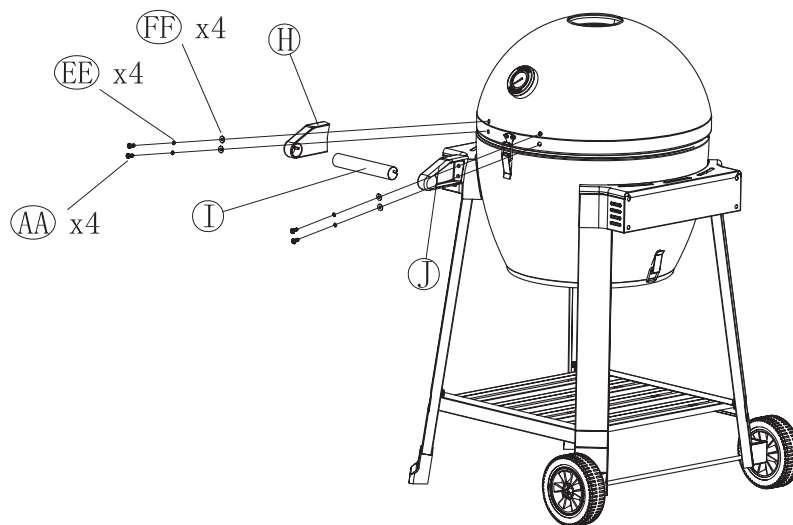

# ASSEMBLY INSTRUCTIONS

## Step 11

- Open the BBQ and attach the Damper (K) and Damper O-Ring Seal (L) on to the hood.
- Secure from inside with two Fibre Washers (GG), two Flat Washers (FF), two Spring Washers (EE) and two Bolts (BB).

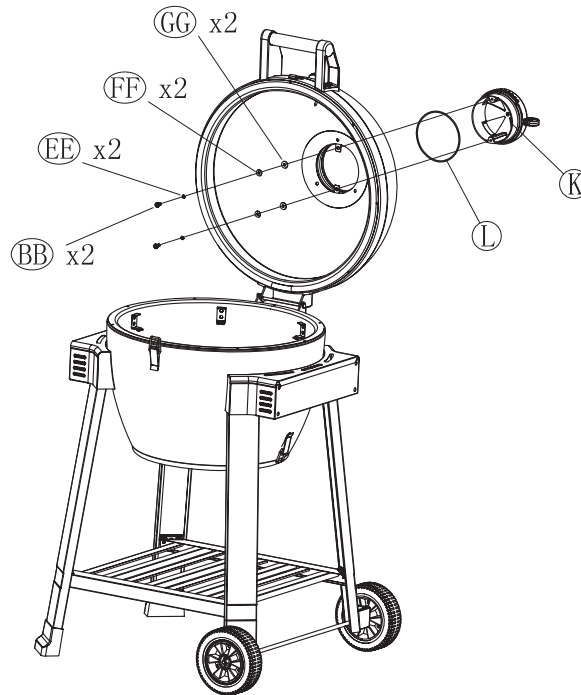

## Step 12

- Loosen the two pre-installed bolts on the left side of the barbeque body, and allow 5mm bolt length to extend. Align the holes on the Table - LEFT (O) with the extended bolts, then push down on the Table until it locates into place, tighten with screwdriver until secure.
- Align the other two holes on the left side of body assembly (A) with the two holes from under the Table Assembly - L (O). Then insert one bolt (AA) into each hole and tighten with screwdriver until secure.
- Repeat the procedure for the Table - RIGHT (P).
- Go back and tighten all bolts with a screwdriver.

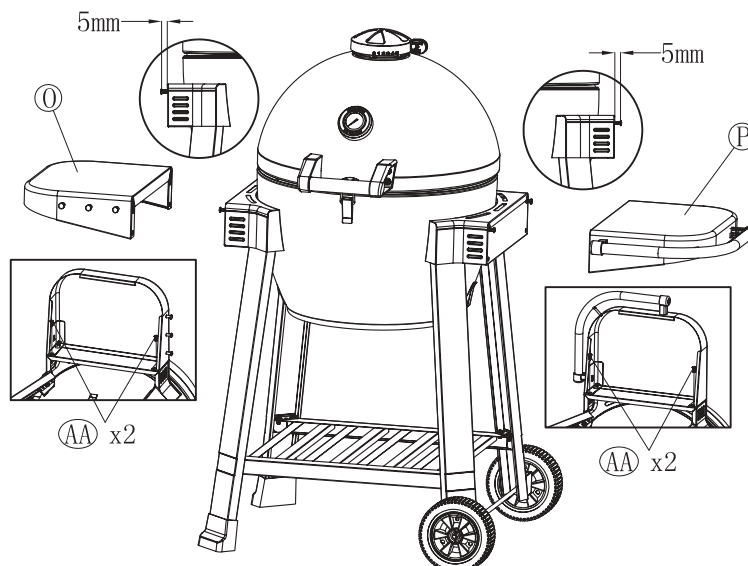

# ASSEMBLY INSTRUCTIONS

## Step 13

- a) With the BBQ hood open, insert the Fire Bowl (M), the Charcoal Grill (E) and Trivet (F) in the order as shown below.

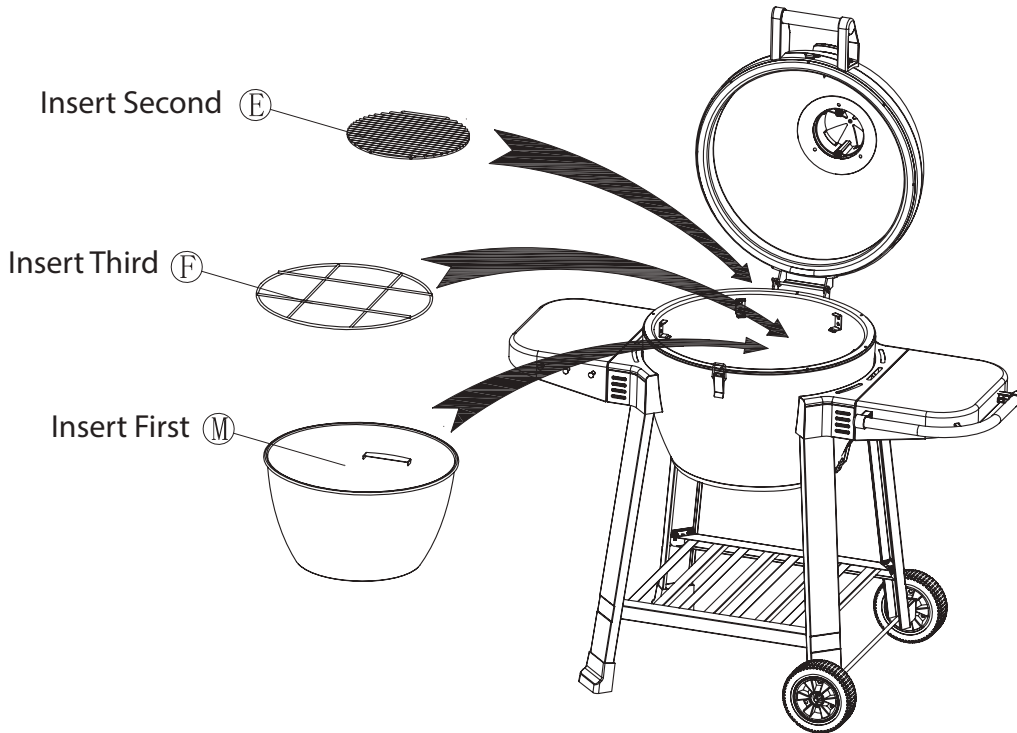

## Step 14

- a) Place the Cooking Grill Outer (C) into the firebox.  
b) Place the Cooking Grill Inner (D) into the middle of the Cooking Grill Outer (C).  
c) Then place the Warming Rack (B) onto the back of the firebox on top of the cooking grills.

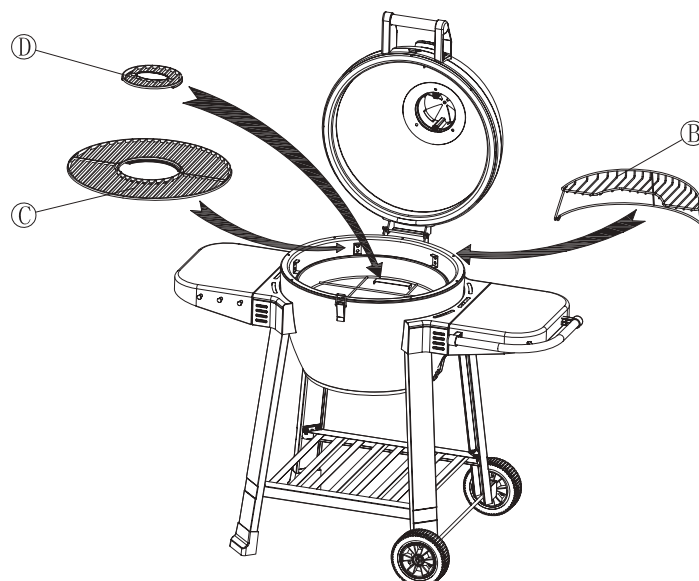

# ASSEMBLY INSTRUCTIONS

## Step 15

- a) Hang the grate lifter on the Table hook for convenience.
- b) Attach the Ashpan (N) onto the bottom part of the firebox and secure it with the two locking clips at the sides as shown below.

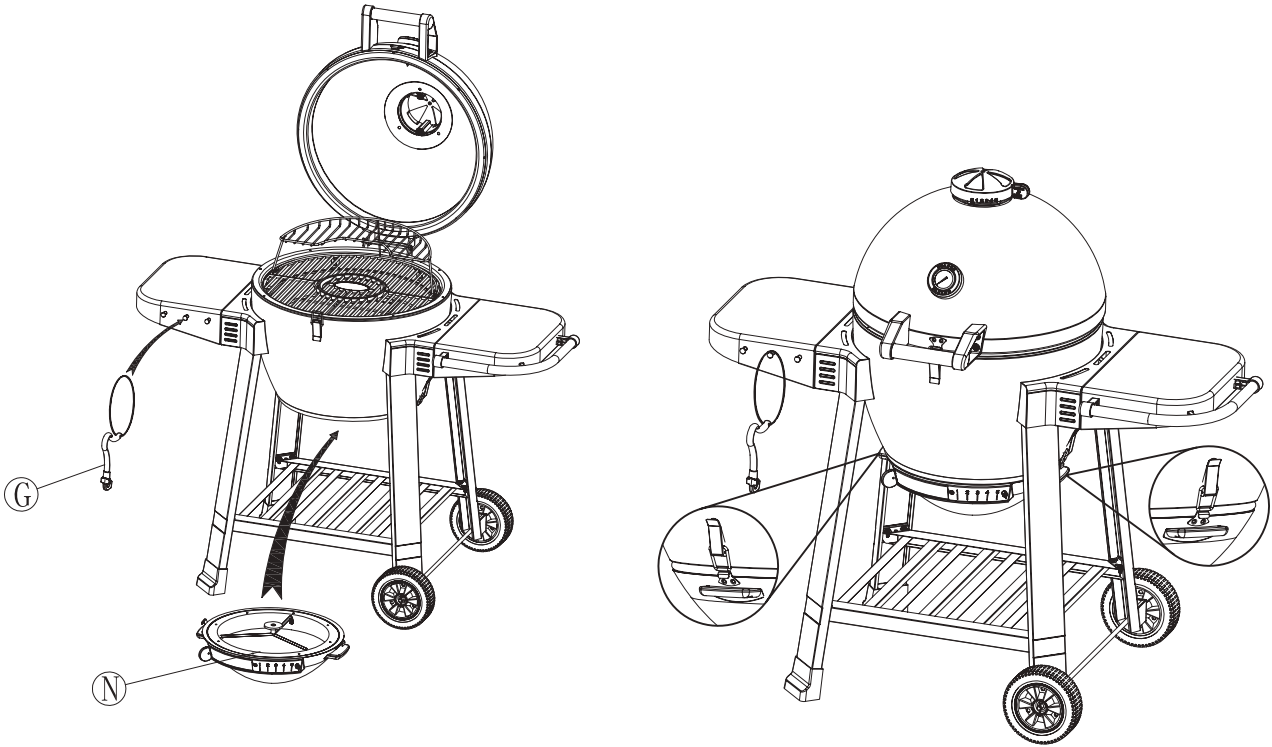

# OPERATING YOUR BARBEQUE

## **Before Lighting**

- Set the BBQ up on a hard non-combustible level surface. The base of the BBQ will get hot so be sure to keep away from areas that could catch fire.
- Be sure charcoal grate is in place in firebox (bottom bowl). Pile charcoal in a pyramid shape on charcoal grate. Ignite charcoal as instructed on charcoal packaging using firelighter or a chimney starter.
- When coals are ashed-over arrange coals evenly over grate with long handled tongs.

## **Food Cooking Information**

- ALWAYS wash your hands before or after handling uncooked meat and before eating.
- NEVER place cooked meat on the same plate that raw meat was on.
- DO NOT use the same utensils to handle cooked and uncooked foods.
- Before cooking ensure barbeque grill surfaces and tools are clean and free of old food residue.

## **After Use Instructions**

- Make sure all coals are fully extinguished and the BBQ is cool.
- Remove ashes.
- Wash BBQ with a mild detergent and rinse with water.
- Wipe dry with cloth or paper towel.
- Clean cooking grill and warming rack with a wire brush.
- Store in dry area.

## **DANGER!**

**DO NOT** use charcoal briquettes for indoor cooking or heating. TOXIC carbon monoxide fumes can accumulate and cause asphyxiation and death!

## **DANGER!**

This BBQ is not intended to be installed in or on recreational vehicles and / or boats.  
Live hot embers can create a fire hazard.

# COOKING INSTRUCTION

## LIGHTING YOUR DRAGON KAMADO

### LIGHTING INSTRUCTIONS

1. Place about 1 to 2kg of charcoal into the fire bowl.
2. Place 1 or 2 Natural Fire Starter Cubes in the charcoal so 1/4 of cube is visible.
3. Open bottom vent fully and leave the hood open.
4. Light the Fire Starter Cubes. Charcoal will be ready in around 15-20 minutes.
5. Close the hood and adjust air flow until the desired temperature is reached. Opening the vents makes the charcoal burn hotter.
6. Pre-heat for 15 minutes prior to cooking. Do not cook before the fuel has a coating of ash.

A charcoal starter chimney is a helpful alternative for lighting.

### CAUTIONS

**Do not use lighter fluid, gas or other combustible liquids to** ignite the Charcoal. Liquid chemicals are a fire and explosion hazard and they will impregnate the ceramic and cause an undesirable taste to food.

**Do not use "Instant Light" briquettes.** This will cause the same undesirable taste.

### CONTROLLING THE TEMPERATURE

1. With the Charcoal fully lit and hood closed, make sure the bottom vent is fully open.
2. Open the top damper vent fully and monitor the temperature until it reaches your desired temperature.
3. Close the top damper vent half way, wait 5 minutes and check the temperature.
4. Adjusting the top damper vent by either closing it more (lower temperature) or opening it more (higher temperature)
5. Monitor the temperature during cooking and if you notice that the temperature has moved outside your desired range, adjust the top damper vent in very small increments and wait 1-2minutes.

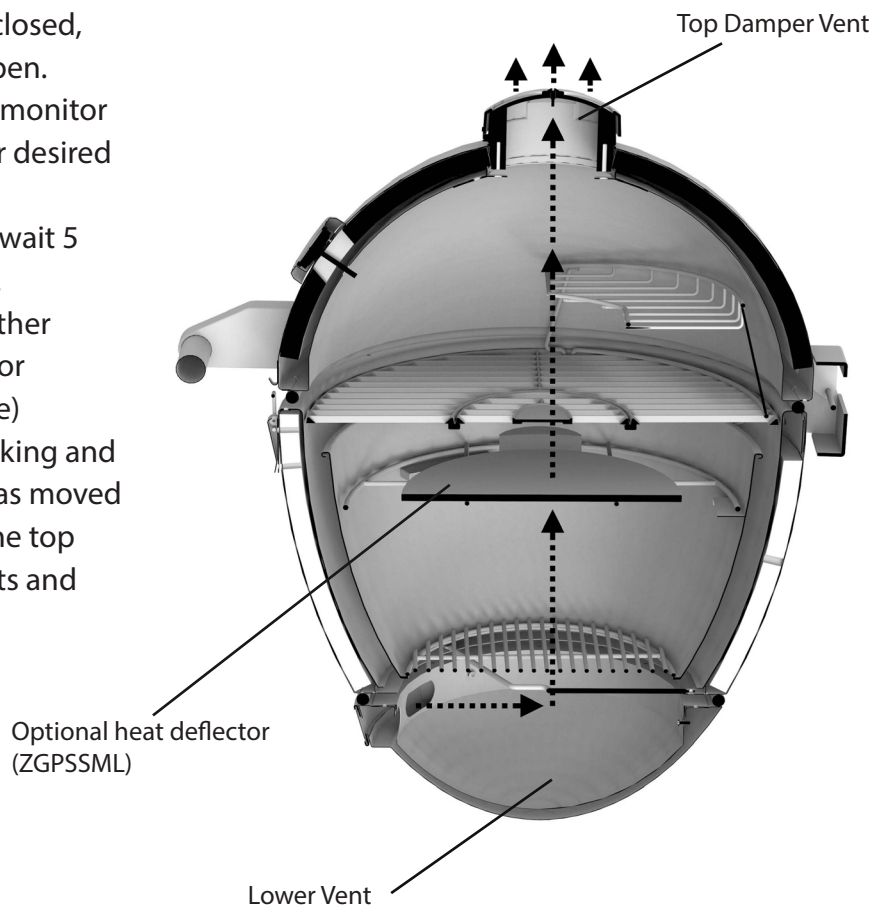

# COOKING INSTRUCTION

## **SLOW COOK/SMOKE (125 ° C to 150 ° C)**

All slow cooking needs an optional Heat Deflector (code ZGPSSML) for indirect heating

Beef, Lamb or Pork	1 hour per kg
Chicken Wings	15 minutes per kg
Full Rack of Ribs	30 minutes per kg
Roasts	30 minutes per kg

## **ROAST/BAKE/GRILL (160 ° C to 250 ° C)**

The times listed below are for cooking directly on the cooking grill, on a roast rack, in a drip pan (direct heating). It is recommended but not vital to use an optional heat deflector (code ZGPSSML).

Chicken (pieces)	30 - 45 minutes
Chicken (whole)	60 - 80 minutes
Pork Tenderloin	20 - 30 minutes
Seafood	5 - 10 minutes
Turkey	2 - 4 hours

## **STEAK HOUSE SEAR (250 ° C to 350 ° C)**

The times listed below are for a meat cooked to “medium”. Adjust the time and temperature to fit your individual taste.

Hamburgers	8 - 10 minutes
Chops	6 - 8 minutes
Steak	6 - 8 minutes

## **BAKING**

For baking, it is usually easier to achieve your desired temperature by keeping the lower vent fully open and only adjusting the top damper vent.

To bake successfully, you will need to use an **optional** heat deflector.

A small pizza stone is great for this. We recommend part code ZGPSSML available from Barbeques Galore stores.

1. Before lighting, fit the trivet. Leave out the heat deflector and the cooking grill at this stage.
2. When the charcoal is fully lit, taking care to avoid burns, fit the heat deflector onto the trivet. Fit the cooking grill in place.
3. Close the hood and preheat for 10 minutes.
4. Make sure the bottom vent is fully open. Open the top damper vent and monitor the temperature until it reaches your desired temperature.
5. Close the top damper vent half way, wait 5 minutes and check the temperature.
6. Adjust the top damper vent by either closing it more (lower temperature) or opening it more (higher temperature).





# COOKING INSTRUCTION

## BAKING (cont.)

7. Once the desired temperature is achieved, set your baking tray in place on the cooking grill. You can also bake on the warming rack. Close the hood and start baking.
8. Monitor the temperature during cooking and if you notice that the temperature has moved outside your desired range, adjust the top damper vent in very small increments, wait 1-2 minutes and re-adjust if necessary.

## ROASTING

For roasting, it is usually easier to achieve your desired temperature by keeping the lower vent fully open and only adjusting the top damper vent.

Some people prefer to use an **optional** heat deflector when roasting. A small pizza stone is great for this. We recommend part code ZGPSSML available from Barbeques Galore stores. You can roast successfully without a heat deflector by using a roast pan topped up with some water under a roast support rack.

1. Before lighting, fit the trivet. Leave out the heat deflector if you are using one and leave out the cooking grill at this stage.
2. When the charcoal is fully lit, taking care to avoid burns, if you are using a heat deflector, fit it onto the trivet. Fit the cooking grill in place.
3. Close the hood and preheat for 10 minutes.
4. Make sure the bottom vent is fully open. Open the top damper vent and monitor the temperature until it reaches your desired temperature.
5. Close the top damper vent half way, wait 5 minutes and check the temperature.
6. Adjust the top damper vent by either closing it more (lower temperature) or opening it more (higher temperature).
7. Once the desired temperature is achieved, set your roast (and drip pan and roast rack if your are using them instead of a heat deflector) in place on the cooking grill. You can also add extra roasting food onto the warming rack. Close the hood and start roasting.
8. Monitor the temperature during cooking and if you notice that the temperature has moved outside your desired range, adjust the top damper vent in very small increments, wait 1-2 minutes and re-adjust if necessary.
9. Use a meat probe thermometer to take the guesswork out of knowing when your roast is done.



# COOKING INSTRUCTION

## GRILLING

For direct grilling, it is usually easier to achieve your desired temperature by keeping the lower vent fully open and only adjusting the top damper vent.

1. Before lighting, take out the trivet. Leave out the cooking grill at this stage.
2. When the charcoal is fully lit, taking care to avoid burns, fit the cooking grill in place.
3. Close the hood and preheat for 10 minutes.
4. Make sure the bottom vent is fully open. Open the top damper vent and monitor the temperature until it reaches your desired temperature.
5. Close the top damper vent half way, wait 5 minutes and check the temperature.
6. Adjust the top damper vent by either closing it more (lower temperature) or opening it more (higher temperature).
7. Once the desired temperature is achieved, set your food in place on the cooking grill. You can grill extra food on the warming rack. Close the hood and start grilling.
8. Monitor the temperature during cooking and if you notice that the temperature has moved outside your desired range, adjust the top damper vent in very small increments, wait 1-2 minutes and re-adjust if necessary.
9. Use a meat probe thermometer to take the guesswork out of knowing when your food is done.

## SMOKING

For smoking, the best way to achieve the lower required temperatures is by almost closing the lower vent. Adjust the top damper vent to control the airflow.

To smoke successfully, you will need to use an **optional** heat deflector. A small pizza stone is great for this. We recommend part code ZGPSSML available from Barbeques Galore stores.

1. Before lighting, fit the trivet. Leave out the heat deflector and the cooking grill at this stage.
2. Take care not to use too much charcoal.
3. When the charcoal is fully lit, taking care to avoid burns, fit the heat deflector onto the trivet. Set your optional smoker box with woodchips and drip pan (if you are using one) into place on top of the heat deflector. Fit the cooking grill in place.
4. Close the hood. Set the lower vent to 1 or 2 marks away from fully closed.
5. Close the top damper vent half way, wait 5 minutes and check the temperature.
6. Adjust the top damper vent by either closing it more (lower temperature) or opening it more (higher temperature).
7. Once the desired temperature is achieved, set your food in place on the cooking grill or on optional smoking racks. You can also smoke on the warming rack. Close the hood and start smoking.
8. Monitor the temperature during cooking and if you notice that the temperature has moved outside your desired range, adjust the top damper vent in very small increments, wait 1-2 minutes and re-adjust if necessary.

# COOKING REFERENCE

## INTERNAL MEAT TEMPERATURES

### Beef

Meat Probe temperature:

Rare 140°F / 60°C Medium 150°F / 66°C Well Done 170°F / 77°C

### Lamb

Meat Probe temperatures:

Rare 140°F / 60°C Medium 150°F / 65°C Well Done 165°F / 75°C

### Veal

Meat Probe temperatures:

Rare not advised Medium 155°F / 70°C minimum safe temperature Well Done 165°F / 75°C

### Pork

Meat Probe temperatures:

Rare not advised Medium 150°F / 65°C minimum safe temperature Well Done 160°F / 70°C

### Poultry

Meat Probe temperatures:

Rare not advised Medium 170-175°F / 75-80°C minimum safe temperature Well Done not advised;

poultry tends to dry out over 175°F / 80°C

**To obtain correct temperature use an instant-read meat thermometer in the thickest part of the flesh, careful not to touch any bone.**

## COOKING TIMES

POULTRY			
Cut of Meat	Weight or Thickness	BBQ Method	Approx Cook Time
Chicken (whole)	2 kg	Indirect	70-80 min
Chicken (halved or quartered)	2 kg total	Indirect	55-65 min
Chicken (breasts, boneless)	150 g ea	Direct	12-15 min
Chicken (breasts, boneless)	150 g ea	Indirect	23-25 min
Wings	120 g	Direct	23-30 min
Wings	120 g	Indirect	35 - 40 min
Cut Up Legs and Wings	2 kg	Direct	10 min
Cut Up Legs and Wings	2 kg	Indirect	40 min
Boneless Cubes (For Kebabs)	2.5 cm	Direct	12-15 min total
Turkey (Whole)	4.5 kg	Indirect	2-3 hours

<b>BEEF</b>			
<b>Cut of Meat</b>	<b>Weight or Thickness</b>	<b>BBQ Method</b>	<b>Approx Cook Time</b>
Roasts	2 kg	Indirect	50 min per kg (rare)
Steaks (T-bone, New York, Porterhouse, Round, Sirloin)	2.5 cm	Direct	5-6 min per side (rare)
Rump Steak	3.5 cm	Direct	5-7 min per side (med rare)
Minute Steaks	0.5 cm	Direct	1.5-2 min per side (rare)
Ground Beef Patties	2.5 cm	Direct	4-5 min per side (rare)
Ground Beef Patties	2.5 cm	Direct	5-6 min per side (med. Rare) Ground
Beef Patties	2.5 cm	Direct	6-7 min per side (well done)
Thermometer Temperature: Rare = 60°C, Medium = 66°C, Well = 77°C			

<b>SEAFOOD</b>			
<b>Cut of Meat</b>	<b>Weight or Thickness</b>	<b>BBQ Method</b>	<b>Approx Cook Time</b>
Whole Fish (with or Without head and tail)	2 kg	Indirect	30-35 min
Steaks & Fillets	2 cm	Direct	3-4 min per side
Prawns	Medium sized	Direct	1.5-2 min per side
Lobster Tails	300 g	Direct	9-13 min
Fish is done when flakes easily when prodded with a fork or knife in the thickest part. Frozen fillets should not be thawed before cooking. Cooking times will be approximately double that of fresh fish			

# CARE & MAINTENANCE

**BEFORE ANY CARE AND MAINTENANCE IS ATTEMPTED PLEASE ENSURE THAT THE BARBEQUE ARE NOT IN USE AND THAT ALL SURFACES HAVE BEEN GIVEN SUFFICIENT TIME TO COOL DOWN.**

Please note the following when maintaining and caring for your barbeque:

- Cleaning your barbeque regularly will help to keep a pristine appearance.
- Throwing cold water over any hot surface of the barbeque is **NOT** recommended and is potentially dangerous.
- Avoid handling and touching hot parts of the barbeque.

## **1. CARE OF THE BARBEQUE BODY**

- Regular care and maintenance of the barbeque body will significantly increase its life and long term appearance.
- Excess grease and fat can be removed using grease remover and warm water with a soft scraper (not metal edged).
- The barbeque body should be fully cleaned by using hot soapy water and a sponge to avoid corrosion starting on dirty surfaces.
- Leave a light film of oil such as cooking spray on the metal parts to assist in rust prevention.
- Regularly spray screws and fasteners with an appropriate lubricant or rust preventer.
- If external paint is scratched or chipped it must be immediately covered with paint or a rust preventer.
- Keep the barbeque covered when it not in use.

# SPARE PARTS

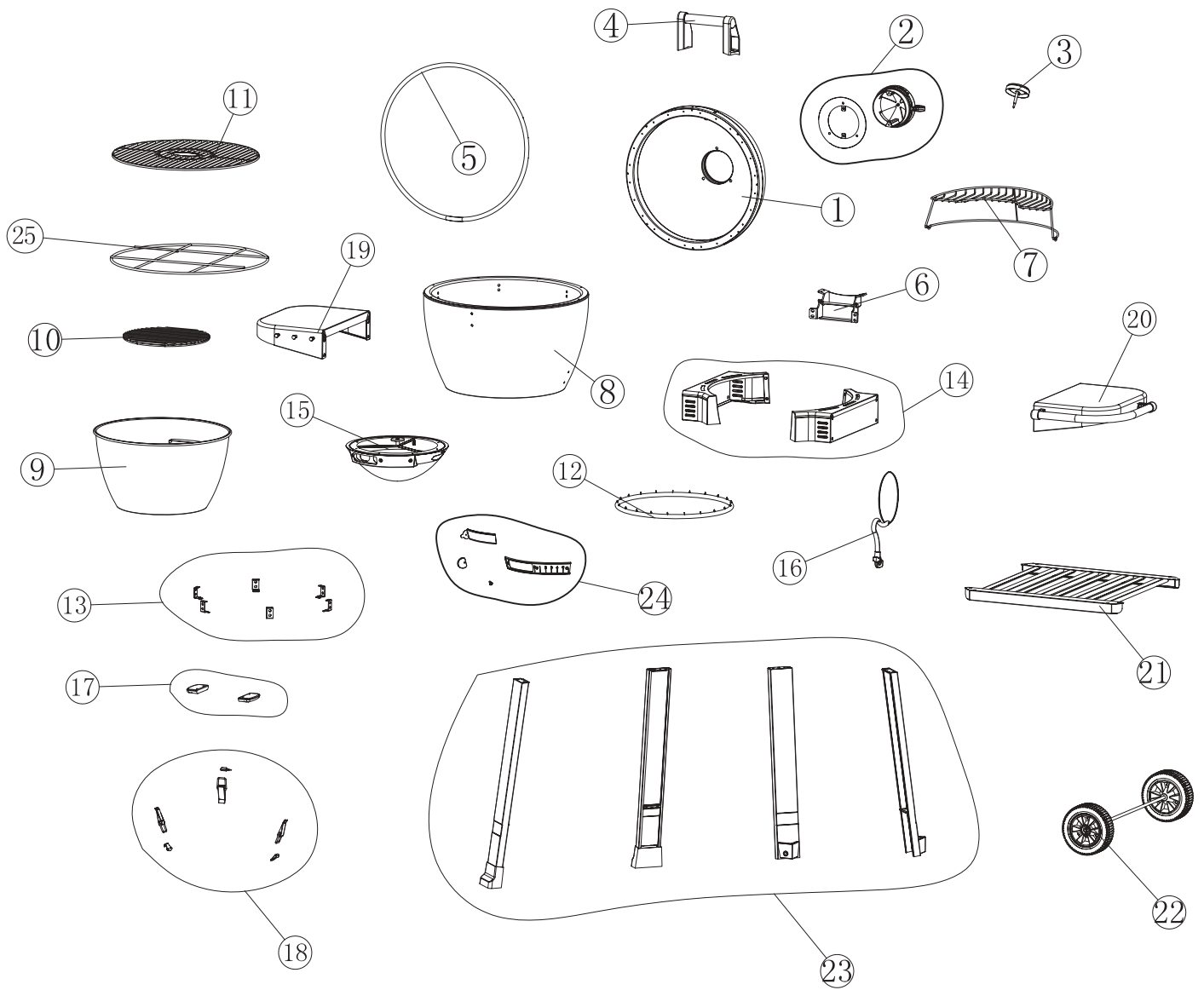

# SPARE PARTS

New parts NO.	GLG Code	QTY used in the BBQ	QTY in PART CODE	Description Line One
1	HHGKEG01G	1	1	HOOD ASSEMBLY GREY
2	HHGKEG02	1	1	DAMPER
3	HHGKEG03	1	1	THERMOMETER
4	HHGKEG04	1	1	HOOD HANDLE ASSEMBLY
5	HHGKEG05	1	1	HOOD SEAT ASSEMBLY
6	HHGKEG06	1	1	Hinge ASSEMBL
7	HHGKEG07	1	1	WARMING RACK
8	HHGKEG08G	1	1	BODY ASSEMBLY GREY
9	HHGKEG09	1	1	FIRE BOWL
10	HHGKEG10	1	1	CHARCOAL GRILL
11	HHGKEG11	1	1	COOKING GRILL SET
12	HHGKEG12	1	1	ASHPAN SEAL ASSEMBLY
13	HHGKEG13	6	6	COOKING GRILL SUPPORT&SCREW

New parts NO.	GLG Code	QTY used in the BBQ	QTY in PART CODE	Description Line One
14	HHGKEG14	2	2	TABLE SUPPORT
15	HHGKEG15G	1	1	ASH PAN ASSEMBLY GREY
16	HHGKEG16	1	1	GRILL LIFTER ASSEMBLY
17	HHGKEG17	2	2	ASH PAN HANDLE
18	HHGKEG18	3	3	LATCH & SCREW
19	HHGKEG19	1	1	LEFT TABLE ASSEMBLY
20	HHGKEG20	1	1	RIGHT TABLE ASSEMBLY
21	HHGKEG21	1	1	BOTTOM SHELF
22	HHGKEG22	1	1	WHEEL ASSEMBLY
23	HHGKEG23	4	4	LEG SET
24	HHGKEG24	1	1	VENT DOOR ASSEMBLY
25	HHGKEG25	1	1	TRIVET
	HHGKEGBP	1	1	BOLT PACK

## **DISCLAIMERS**

- The manufacturer reserves the right to change and amend the specifications without prior notice.
- Failure to follow the instructions in this manual will void any warranties offered on the product.
- Modifications to the barbeque in any fashion will null and void the warranty of the item.

## **More Information?**

Need more information or assistance in anyway? You can call your nearest Barbeques Galore store where barbeque experts will be happy to help you. Just phone

**1 8 0 0 9 7 8 5 5 5**

Or visit our website at

[www.barbequesgalore.com.au](http://www.barbequesgalore.com.au)