

Norseman

Owners manual for

Norseman Aura MKII Wood Heater



**PLEASE ENSURE ALL PACKAGING MATERIALS
ARE REMOVED FROM THE FIREBOX BEFORE
YOUR FIRST FIRE.**

Tested and approved to Australian Standards
AS/NZS 2918:2018 and AS/NZS 4013/4012:2014.

Prior to installation check with your state and local
authorities regarding any specific regulations that
may apply.

Please keep these instructions for future reference.

Burn hardwood only.



Barbeques Galore is a
proud member of the
Australian Home Heating
Association

**BARBEQUES
GALORE**

FIRST THINGS FIRST...

Congratulations on your purchase of a quality Norseman wood heater. This product is designed according to strict environmental, quality and safety standards and should give you years of trouble free home heating.

Read these instructions carefully to get the most out of your heater and to ensure safe and satisfactory heater performance. In particular, we would like to draw your attention to these warnings.

Be careful of what you burn:

- * Use only dry, well seasoned hardwood.
- * Do not use coal or briquettes.
- * **WARNING: DO NOT USE FLAMMABLE LIQUIDS OR AEROSOLS TO START OR REKINDLE THE FIRE.**
- * Do not burn garbage in the firebox as garbage can cause a dangerous soot build up and increase the amount of smoke your heater produces.
- * Do not burn chemically treated timber as the poisonous gases given off could damage your stove.
- * CAUTION: THE USE OF SOME TYPES OF PRESERVATIVE-TREATED WOOD AS FUEL CAN BE HAZARDOUS.
- * Do not place any types of builders board eg fibro, cement sheeting (or any other materials not specified and tested by the manufacturer) inside the firebox.

Protect yourself and your family from burns:

- * **WARNING: OPEN AIR CONTROL BEFORE OPENING FIRING DOOR.**
- * The exterior surfaces of the heater will become hot during operation. For protection of children, the elderly or infirm, provide a firescreen to prevent contact with the appliance in operation.
- * To protect against injury from burns, use caution when operating the appliance. In particular, when loading the firebox, provide adequate protection for your hands.

Exclusion of Liability

Whilst every care has been taken in formulating these instructions, no responsibility whatsoever will attach to and/or claim lie against, the manufacturer and/or the distributor of the heater as a result of any failure to follow the whole or any part of the instructions and/or as a result of incorrect information herein and/or any omission here from.

Use your heater according to these instructions:

- * CAUTION: THIS APPLIANCE SHOULD BE MAINTAINED AND OPERATED AT ALL TIMES IN ACCORDANCE WITH THESE INSTRUCTIONS.
- * **DO NOT BURN WITH DOOR OPEN.**
- * CAUTION: THIS APPLIANCE SHOULD NOT BE OPERATED WITH A CRACKED GLASS.
- * Do not throw logs into the firebox. Always place logs carefully.
- * Load logs with ends pointing to the front of the heater. This will help prevent logs rolling forward.
- * Do not overfire (allow firebox to glow red) as this could damage your firebox.
- * Always leave a minimum of 25mm (1") of ash in the bottom of the firebox. Never empty it completely.
- * **WARNING: ANY MODIFICATION OF THE APPLIANCE THAT HAS NOT BEEN APPROVED IN WRITING BY THE TESTING AUTHORITY IS CONSIDERED AS BREACHING AS/NZS 4013.**
- * The appliance or flue system should not be modified in any way without the written approval of the manufacturer.

The heater can get very hot, so watch obvious fire hazards:

- * Do not place clothing or other combustible materials on top of the heater.
- * **WARNING: DO NOT USE FLAMMABLE LIQUIDS OR AEROSOLS OR PLACE THESE IN THE VICINITY OF THIS APPLIANCE WHEN IT IS OPERATING.**
- * **WARNING: DO NOT STORE FUEL WITHIN HEATER INSTALLATION CLEARANCES.**
- * Do not store flammable liquids near the heater.
- * Do not store fuel close to the stove.

INSTALLATION - GENERAL NOTES

Before Beginning

Before beginning the installation of your wood heater, you should note the following precautions:

- * **WARNING: THE APPLIANCE AND FLUE-SYSTEM SHALL BE INSTALLED IN ACCORDANCE WITH AS/NZS 2918 AND THE APPROPRIATE REQUIREMENTS OF THE RELEVANT BUILDING CODE OR CODES.**
- * **WARNING: APPLIANCES INSTALLED IN ACCORDANCE WITH THIS STANDARD SHALL COMPLY WITH THE REQUIREMENTS OF AS/NZS 4013 WHERE REQUIRED BY THE REGULATORY AUTHORITY I.E. THE APPLIANCE SHALL BE IDENTIFIABLE BY A COMPLIANCE PLATE WITH THE MARKING 'TESTED TO AS/NZS 4013.**
- * **WARNING: ANY MODIFICATION OF THE APPLIANCE THAT HAS NOT BEEN APPROVED IN WRITING BY THE TESTING AUTHORITY IS CONSIDERED TO BE IN BREACH OF THE APPROVAL GRANTED FOR COMPLIANCE WITH AS/NZS 4013.**
- * **CAUTION: CRACKED AND BROKEN COMPONENTS, e.g. GLASS PANELS OR CERAMIC TILES, MAY RENDER THE INSTALLATION UNSAFE.**
- * It is strongly recommended that a certified/qualified installer perform the installation.
- * You may need to get council approval prior to installation.
- * You should also check with your insurer for any requirements they may have.

Flue Installation

The correct flue system is critical to the performance of your wood heater. It must either be tested with the heater or be a default flue kit.

The flue must be sealed where it enters the heater at the flue spigot.

We recommend you use a Maxiheat Default Flue Kit.

CAUTION: MIXING OF APPLIANCE OR FLUE-SYSTEM COMPONENTS FROM DIFFERENT SOURCES OR MODIFYING THE DIMENSIONAL SPECIFICATION OF COMPONENTS MAY RESULT IN HAZARDOUS CONDITIONS. WHERE SUCH ACTION IS CONSIDERED, THE MANUFACTURER SHOULD BE CONSULTED IN THE FIRST INSTANCE.

Flue Height Requirements

Your flue must extend the required height above your roof to promote sufficient draught. If the flue is not high enough, the heater will not "draw" properly causing smoke to spill back into the room.

The following conditions should be observed:

- * The minimum height of the active flue must be 4.6m in length measured from the top of the hearth to the flue termination point.
- * If the flue terminates within 3 m from the highest point of the roof, then the flue must be a minimum of 0.6 m above the highest point.
- * If the flue terminates further than 3 m from the highest point of the roof, then the flue must be a minimum of 1 m above roof penetration.
- * The flue must clear any ridge or obstruction within a 3m radius by a minimum of 1m.

The installer must ensure that the heater and flue are correctly and safely installed in accordance with AS/NZS 2918.

There are other variables that can affect draught (eg trees or tall buildings nearby). If you have the correct flue height and still have problems, consult your dealer.

INSTALLATION - FREESTANDING MODEL ONLY

Location

Select a location for your wood heater with great care.

- * Do not place your heater in areas of high traffic, near furniture or draperies.
- * Check that the intended location will not interfere with ceiling joists, rafters, valleys and ridges.

Hearth Requirements

If your wood heater is to be installed on carpet, timber or any other combustible material, you must place a hearth (also known as a floor protector) underneath the heater. Please observe the following:

- * The hearth must consist of at least 18 mm thick with a thermal conductivity not greater than 0.33 W/m²K
- * The hearth must be no less than 1150 mm wide
- * It is not recommended that you make your own hearth
- * The hearth and heater assembly must be placed on a firm and level surface.

- * **Please note the heater clearances are to the upper body of the heater and not to the bench.**

Hearth Clearances

It is necessary to ensure that the heater is positioned on the hearth so that the following requirements are observed:

- * The front of the hearth should extend past the front of the heater by 600 mm.
- * The side of the hearth should extend past the firebox opening by minimum 200 mm on each side.

Heater Clearances

It is vital that the heater be installed the proper distance from combustible surfaces like wood, gyprock and curtains. These minimum distances, which you need to observe for your particular heater are stated below. The diagrams show both parallel and corner installations.

Failure to maintain these minimum distances may result in a fire for which your insurer may refuse to cover.

Reduced Clearances

These clearances can be reduced with proper heat shielding. Basically a noncombustible surface is placed between the heater and the combustible wall. It is vital that an unobstructed air flow be maintained between the two surfaces to remove excess heat.

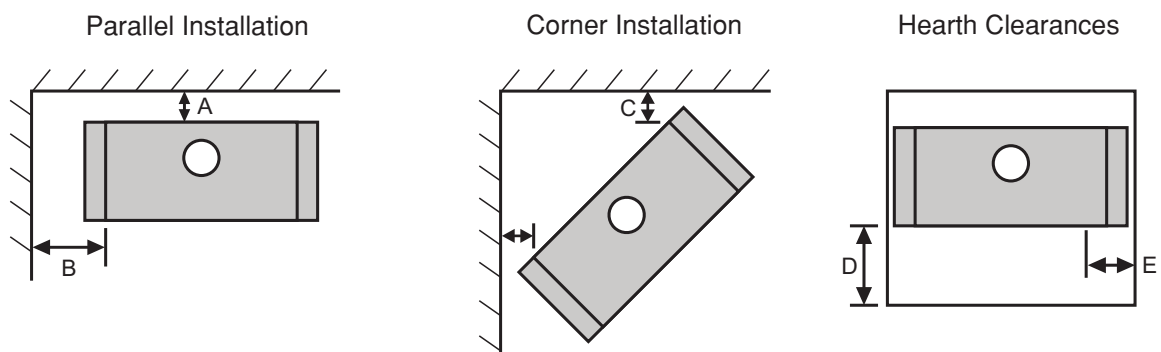

Clearances (All dimensions are in millimetres)	A	B	C	D	E
Maxiheat Non-Perforated Flue Kit with Inner Shield (MXFKSD3MB)	400	400	100	600	200
Maxiheat Non-Perforated Flue Kit with Inner and Additional Outer Shield (MXFKSD3MB + MXRSOB2)	300				
Maxiheat Standard Default Black Painted Flue Kit with Double Shield (MXFKT3MB)	250				
Maxiheat Insulated Room Sealed Flue Kit with Flue Shield (MXFKRS3MBWS)	300				

INSTALLATION - INSERT MODEL ONLY

Your insert heater comes with a zero clearance outer casing, which allows it to be fitted into a combustible wall using the frame dimensions and clearances below.

The appliance must be installed by a qualified wood heater installer according to the latest version of AS2918. Please note that the enclosure must be sealed from external draughts and vermin.

Clearances to Combustibles

The diagram below shows the minimum clearances (in millimetres) from the zero clearance box to combustible materials.

The clearances include distances to the timber framing, any side walls and to the ceiling.

- There must be no less than 350 mm between the floor and the bottom of the zero clearance box (this refers to the bottom face of the support channels).
- There must be no less than 30 mm between the side of the zero clearance box and any combustible material.
- There must be no less than 450 mm between combustible side wall and the side of the zero clearance box.
- There must be no less than 400 mm between the top of the zero clearance box to any internal structural timbers. Please note you may need to use a metal brace to support the cladding directly above the heater.

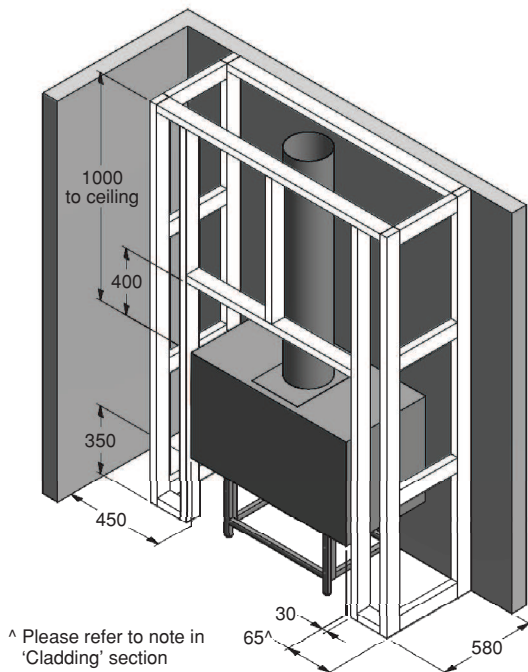

Hearth Construction

If you are installing your heater on a combustible heat-sensitive floor, then you must use a hearth with your heater.

The hearth shall consist of no less than 5 mm thick compressed fibre cement sheet. The cement sheet shall have thermal conductivity not greater than 0.33 W/m²K.

The hearth must extend a minimum of 300 mm in front of the heater and no less than 200 mm from either side of the door opening. The hearth must be a minimum 1150 mm wide.

Cladding

The frame and cladding must extend to the ceiling.

The front wall of the enclosure must consist of non-combustible material. The non-combustible material must extend from the floor protector to a minimum height of 1000 mm above the top of the zero clearance box.

For ease of construction, it is recommended that the full height of the front wall be constructed of non-combustible material.

The non-combustible material must extend no less than 65 mm either side of the zero clearance box. If desired, the width of the front wall may be extended.

Please refer to the following page for diagrams and further details.

INSTALLATION - INSERT MODEL ONLY

Cladding Installation

Please note that the heater fascia is smaller than the front of the zero clearance outer casing. So, when you are fitting the cladding to your enclosure, you will need to 'sandwich' the cladding in between the heater fascia and the zero clearance casing.

Please refer to the following steps to assist you in fitting the cladding to the front of your enclosure.

Before you proceed, we recommend you remove the door by lifting it up and off the hinge bracket.

1

Remove the Fascia

- a. Firstly, remove the bottom bar from the fascia assembly. Lift the bottom bar up and away from the fascia assembly.

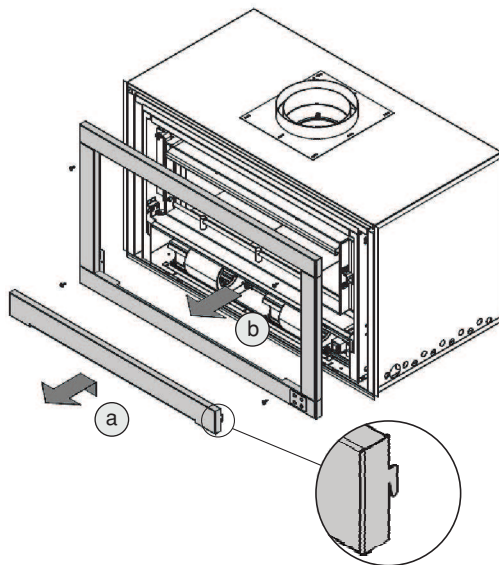

- b. The fascia body is attached by 4 screws. Remove these screws and set them aside. Carefully slide the fascia forward to remove.

Please be aware that the fan wiring is connected to the rear of the fascia. This wiring will need to be disconnected prior to installing the cladding. You will need to reconnect the wiring, so please take note of the connections.

If unsure of any electrical connections or any problems arise, please contact an electrical contractor.

2

Reposition Heater Body

There are 2 screws holding the heater body to the zero clearance casing. These are located at the bottom, in front of the fans. Undo these 2 screws and set aside.

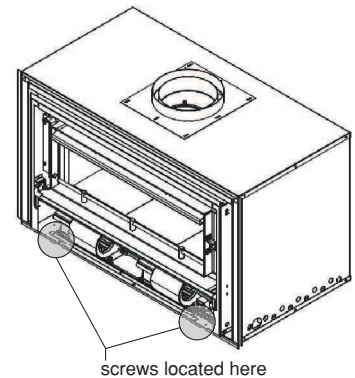

Slide the heater body forward to allow for the cladding to fit in between the zero clearance casing and the heater body.

The gap shown below only needs to accommodate the thickness of the cladding.

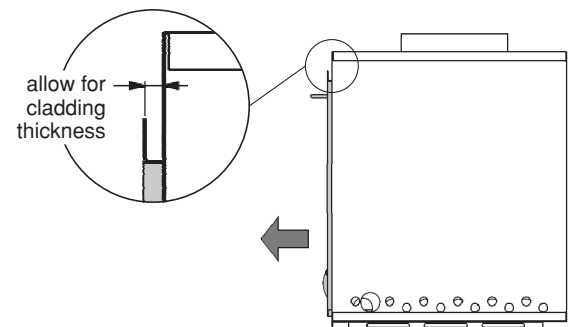

3

Cladding Cutout Dimensions

The cutout for the cladding should be 585 mm high by 980 mm wide.

The bottom of the cutout should sit up against the base of the heater body casing.

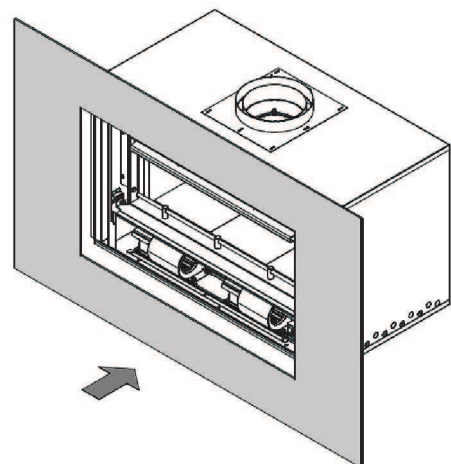

Follow step 1 in reverse to reattach the fascia.

INSTALLATION - INSERT MODEL ONLY

Ventilation

Ventilation to the enclosure is required to allow air to flow through the enclosure and maximum heat return. The air vents can be placed on the sides of the enclosure or on the front.

The vents need to have a minimum open area of 19,600 mm² (9,800 mm² top and 9,800 mm² bottom) and must be placed at the top and bottom of the enclosure.

The bottom air vents must not be installed any higher than 200 mm above the floor and the top air vents must not be installed any lower than 215 mm from the ceiling.

Examples of typical installations are shown in the following diagrams:

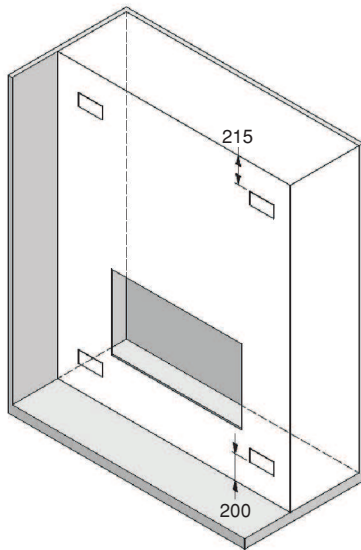
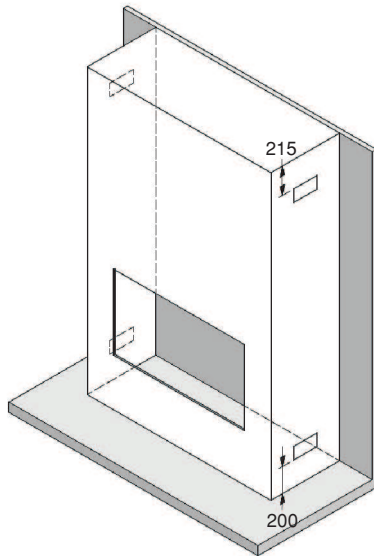

Heater Dimensions

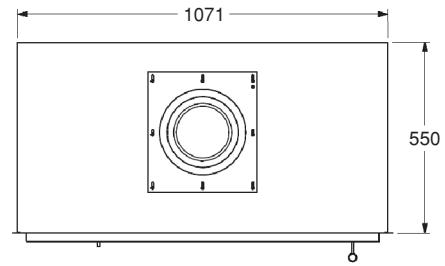

Top View

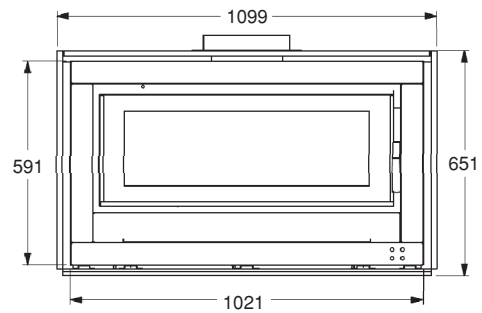

Front View

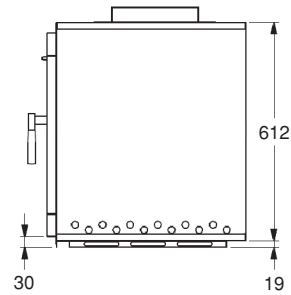

Side View

ASSEMBLING YOUR NEW HEATER

- BENCH AND WOOD STACKER FOR FREESTANDING MODEL

The heater body can be placed on either a bench or wood stacker stand.

We recommend you place the bench or wood stacker in its final position before fixing the heater body into place.

Bench Assembly

Before you fix the heater body to the bench, please ensure the final bench position is understood and all relevant clearances are observed

Please note that the bench comes pre-assembled

1

Remove bench from packaging and move into position

2

Place Heater Body onto Bench

Ensure Bench is located in final position, observing all relevant clearances

Ensure Heater Body is centrally located on bench and assembly holes in bench and pre installed thread in head unit align

3

Attach Heater Body to Bench unit

Using the 4 provided bolts and washers, attach the heater body to the bench unit by screwing the bolts into the manufactured threads from below the unit

Wood Stacker Assembly

Before you fix the heater body to the wood stacker, please ensure the final position is understood and all relevant clearances are observed

Please note that the wood stacker comes pre-assembled

1

Remove Wood Stacker from packaging and move into position

2

Place Heater Body onto Wood Stacker

Ensure Wood Stacker is located in final position, observing all relevant clearances

Ensure heater body is centrally located on Wood stacker and assembly holes in bench and pre installed thread in head unit align

3

Attach Heater Body to Wood Stacker unit

Using the 4 provided bolts and washers, attach the heater body to the wood stacker unit by screwing the bolts into the manufactured threads from inside the Wood Stacker

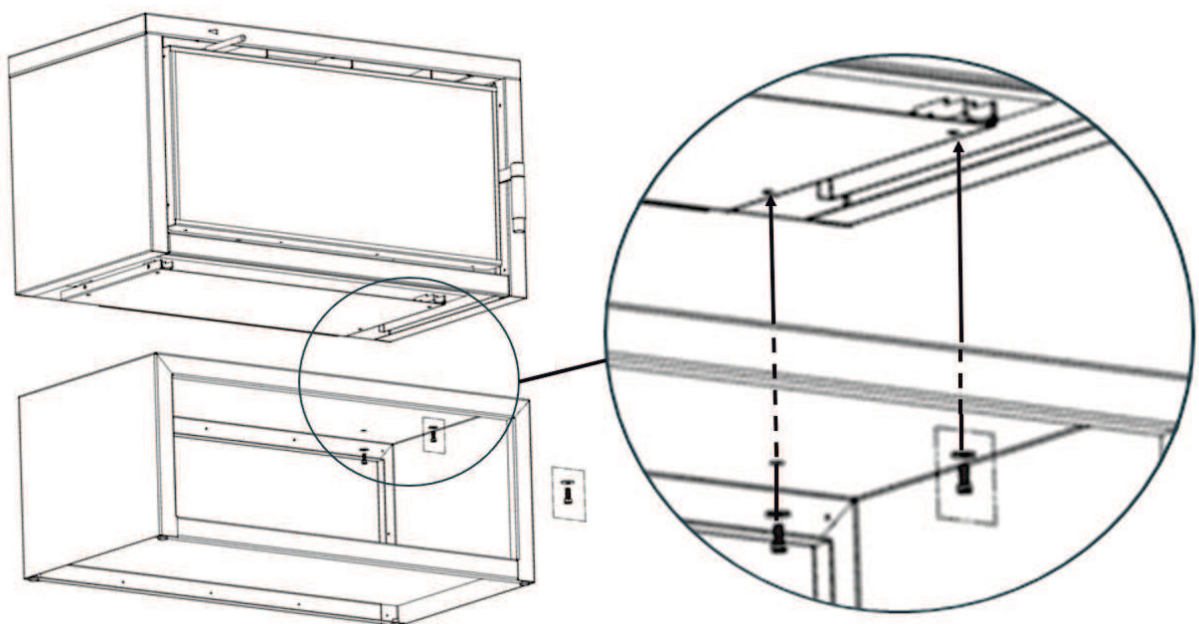

ASSEMBLING YOUR NEW HEATER

- INSTALL ON CONCRETE BENCH

The Aura MKII can also be installed directly onto a Concrete Slab or similar sturdy, non-combustible, structure. Please see below on how to install this. As always, it is strongly suggested that the physical product is present before any design or construction costs are incurred to protect against any unforeseen challenges

1 . Concrete Bench Requirements

- * The concrete slab or bench must be structurally adequate to support the combined weight of the heater and the complete flue system
- * Construction shall comply with all relevant building regulations and applicable standards.
- * The slab must be level, non-combustible, and permanently fixed.
- * Minimum clearance requirements for the Aura MKII heater, as found on page 4 must be fully achieved and maintained on all sides of the appliance.
- * **The Bench Height must exceed 395mm from the floor to the bench top surface**

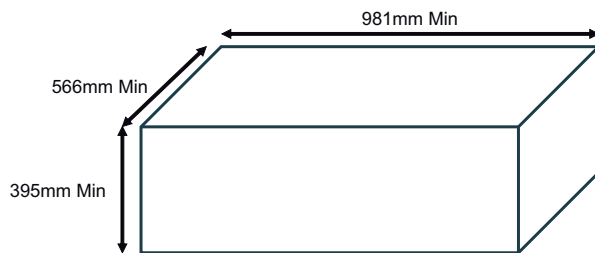

Please Note

- * Above are Minimum Measurements
- * If Bench is to extend to Combustible Surface at rear, Minimum clearance (dependent of flue kit type) must be taken into account. In this case, minimum bench size will equal heater depth (496mm) Plus flue kit Clearance.
- * If Bench is to extend to Combustible Surface left or right, side clearance of 400mm must be added.

2 . Install Location Feet

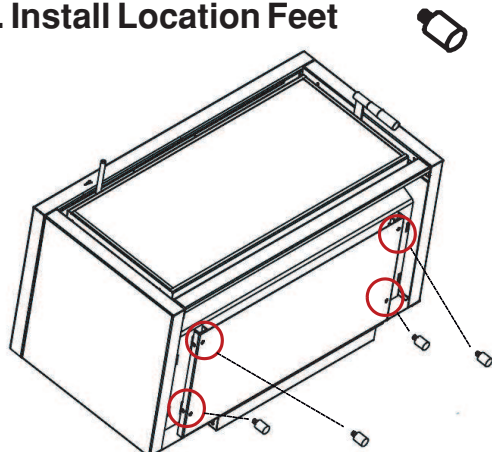

2 . Install Location Feet Cont.

- * Carefully place heater on its back, with protection to ensure no damage to unit
- * Screw in 4 Location feet to the base of the unit as per below

3 . Mark and Drill Location Holes

- * Carefully place heater on bench and ensure minimum clearance requirements for the Aura MKII heater, as found on page 4 are fully achieved and maintained on all sides of the appliance.
- * Mark out location of feet on bench. Use following diagram as a guide for hole spacing
- * Drill 4 holes, in corresponding feet location, that are greater than 18mm but no more than 20mm in diameter and no less than 20mm deep, in bench top.
- * Ensure all holes are clean and free of dust and debris.
- * Reinstall unit onto bench, ensuring location feet are fully located within the location holes.

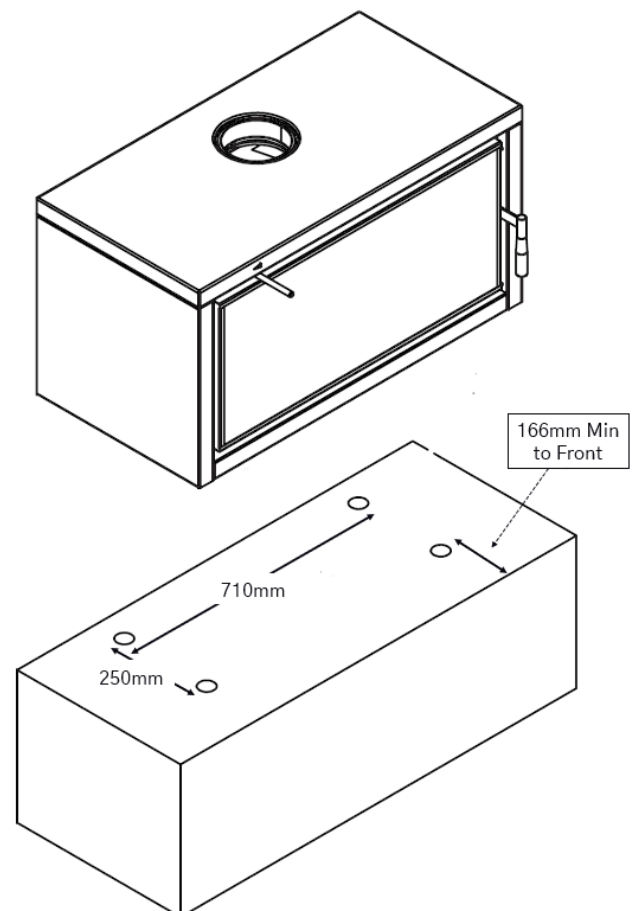

ASSEMBLING YOUR NEW HEATER

- FREESTANDING AND INSERT MODEL

Once your heater is in place, there is only a simple matter of putting the firebricks and baffle plate into place and your heater is ready to use.

Firebricks and Baffle Plate

The firebricks and baffle plate **MUST** be installed prior to operating the appliance. Refer to the following diagrams to ensure that they are installed correctly.

Place the rear and bottom firebricks in first. Please note that these firebricks are similar in size. The rear firebricks are 200 mm high by 275 mm wide. The bottom firebricks are 270 mm deep by 255 mm wide.

Place the rear brick retainer over the rear firebricks.

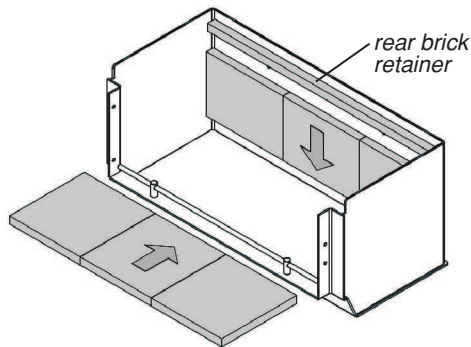

The side firebricks have an angled cut on the top edge. Place these firebricks into the firebox so that the shorter edge is at the rear of the firebox and the longer edge is at the front.

The top face of the front firebricks are cut at an angle. Place these firebricks into the firebox so that the top face sits horizontally.

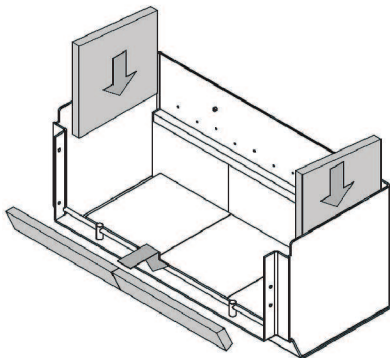

Next, place the rear baffle holder into the firebox. This sits on top of the side firebricks at the rear of the firebox. There are two locating holes in the holder that sit over pins in the rear of the firebox.

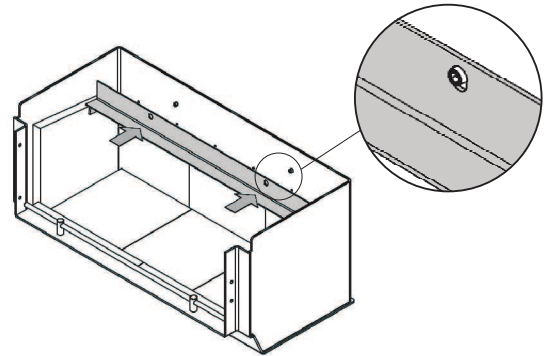

Place the front baffle holder into the firebox. This sits on top of the side firebricks towards the front of the firebox. There are two locating holes in the holder that sit over pins at the front of the firebox.

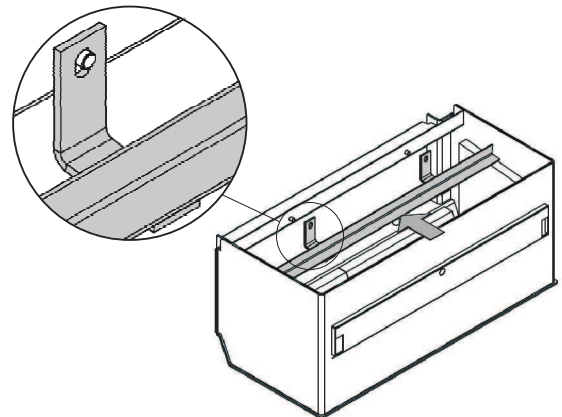

The baffle comes in 3 pieces with cutouts along the edges to allow them to nest together.

Place the two side baffle pieces in first, then put the middle baffle piece in place.

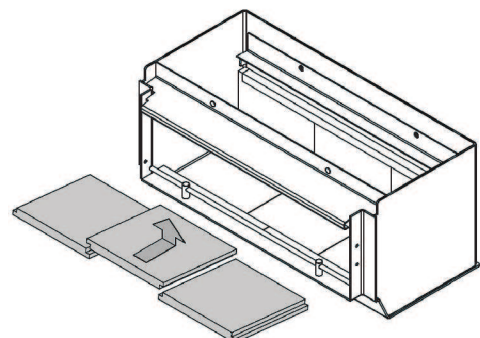

***Please Note**

Baffle insertion is only required for inbuilt model. Freestanding model has baffle already fitted at time of manufacturing

WOOD SELECTION

Few things affect the performance of your heater as much as the fuel you burn. Take note of the following:

What Not To Burn

- * Softwood (except kindling)
- * Wet or unseasoned wood
- * Treated or painted timber
- * Saltwater wood
- * Coal or charcoal
- * Garbage, plastic etc
- * Any solvents, kerosene, petrol or any flammable liquid.

What To Burn

Quite simply, dry seasoned hardwood.

From when wood is first cut down, it takes up to 12 months of dry storage for the wood to season properly. The seasoning process is underway when cracks begin to appear at the ends of cut timber.

Use of moist or unseasoned wood will result in excessive smoke, longer startup times, a lazy flame that requires more air to stay alight, creosote build up in the flue and on the door glass, and a much less powerful fire. The reason is simple. Heat that would normally be going into the room is wasted boiling water that is trapped inside the wood. This poor performance costs you money in wasted fuel and increased maintenance.

It is difficult to determine if wood is dry just by looking at it. If you can hear the wood sizzle and hiss, or can see moisture bubbling from the wood surface, then your wood is too wet. In practice, the best thing you can do is to be sure of the source. Buy your wood from reputable wood merchants. Make sure you store the wood correctly.

Wood Storage

It is important that wood be stored under cover. Even wood that is years old will absorb large quantities of moisture if exposed to the elements.

It is advisable that wood is stacked to allow some air flow in and around the logs. This will help keep the wood dry.

Wood Splitting

It is best to have on hand a good range of wood sizes to help control the fire. The rule of thumb is: the hotter the fire, the bigger the log you can put in.

- * You need very small pieces of kindling to get the fire started efficiently.
- * Small pieces up to about 50mm thick are good when the fire is still being established, or when you want to revive a fire that has burnt low.
- * Larger logs are excellent for long burns once the fire is well established.

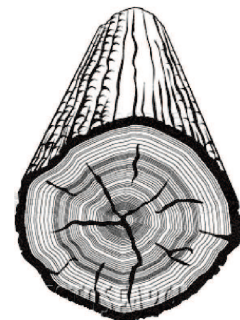

USING YOUR HEATER

Before using your wood heater, study this entire section carefully. It will assist you in achieving maximum efficiency and enjoyment.

Curing the Paint

Various parts of your heater have been coated with high quality paints to protect them and to give them an attractive finish. You will need to "break-in" your heater to harden or cure these coatings.

While curing, be careful not to touch the painted surfaces as the paint will be quite soft.

The basic rule is: cure slowly, over about three burns, without a hot fire. During the curing process it is normal for some smoke and smell to be given off from the surface of the heater. Each time, some windows should be opened to allow the paint odours to escape. Using a fan also helps disperse the odours. For this reason it is best done during the day.

1. The first fire should be kindling only and should last for about 20 minutes. Leave the door slightly ajar to stop the door rope from sticking.
2. Once the heater has cooled down, repeat the process.
3. The third fire should be a normal fire of at least 45 minutes.

By this time, your heater should be cured. In colder conditions, or if the heater uses a fan, it may take slightly longer. The house should be ventilated until all odours are gone.

Operating The Air Control

You can control whether your heater burns on high or low with the air control lever found on the front of the heater. The high and low position is clearly marked on your heater.

For low burns - Use this setting for low burning, or for extended burn times.

For medium burns - This is the optimal setting for normal use.

For high burns - Use this setting for starting the fire and for at least 30 minutes after loading and reloading.

Lighting The Fire

Wood burns most efficiently when placed in a very hot fire. These procedures are designed to bring your firebox to the right temperature as quickly as possible.

Put the air control on high.

Place a large amount of kindling in a criss-cross pattern over a firelighter. Make sure plenty of air can get into the stack and around each piece of kindling.

Add a few small pieces of wood on top. The firebox should be about half full of fuel.

Ignite the firelighter.

Continue to add small pieces of wood until a bed of hot glowing coals is established.

Place two or three thoroughly dry split logs (about 80-100mm diameter) on the well established fire. Logs will burn better if they are placed with their ends near the glass, ie front to back.

Leave the air control on high for about 30 minutes. After this time, the firebox should be hot enough for normal operation, so you can turn down to medium or low.

Adding fresh wood cools the fire down, so when you need to replenish the fuel, turn the air control to high for about 30 minutes to bring the firebox temperatures back up to normal

Always leave the air control on high for at least 30 minutes after reloading.

USING YOUR HEATER

A Few Hints

Wood should be stacked front to back - with the ends facing the door - and with space between them for air to flow around.

The door should remain closed at all times except when first establishing the fire and when loading.

There are many factors that can affect the way your heater burns, including flue height, wood type, shape, amount, the way it is stacked, wind conditions and outside air temperatures to name a few. You will find that before long you will get to know how your heater works best for you.

Overnight Burns

Large unsplit logs are the best fuel to use.

Make sure you have a good strong bed of glowing coals and the heater is hot before loading the logs.

Place a load of wood on the strong base fire and coals, shut the door and leave on high for about 30 minutes or until the logs are charred all over.

Turn down to low.

Restarting After an Overnight Burn

Adjust air control to high.

Rake the hot coals.

Place some kindling and small logs on the coals.

Once the fire is established, start putting on larger logs.

Removing Ashes

When the ashes are level with the firebox opening, it's time for a clean out. This should only be done when the firebox has completely cooled. Removing hot ashes is hazardous.

Push chunks of charred wood to one side. These will burn in the next fire, so it would be a shame to waste them. Using a metal scoop, remove excess ash and place in a metal container.

You should leave a small amount of ash in the firebox to provide an insulating base for the next fire. Rake them over so they form a flat bed.

When disposing of the ashes, keep them in a metal or other non-combustible container with a tight fitting lid. Move them outdoors immediately to an area clear of combustible materials. Do not place them in plastic receptacles.

Door Handle

The door handle on your heater will become very hot during operation, especially during high burns.

We recommend you wear gloves to open the door.

Heater Fan

Your Norseman heater is fitted with two fans. The fan should only be used on "high" or "boost" when the air control is on the maximum setting.

The fan should never be used when the air setting is on "low" or overnight setting.

We also recommend not using the fan until 30 minutes after the fire is first lit.

CARE AND MAINTENANCE

Your heater has been designed as a heavy duty appliance capable of withstanding normal operating conditions.

Care

The firebox liners where fitted must be treated with care. Avoid throwing logs into the firebox as this may fracture the liners.

Cleaning

Painted surfaces: to clean painted surfaces, wipe over with a soft, damp cloth. Do not use harsh solvents and cleaning agents as these can damage the coating. Buff dry with a soft, dry cloth.

If your heater is installed in a coastal environment, where salt air will come in contact with the heater, this cleaning process should be performed weekly to avoid the salt causing deterioration of the paint and subsequently rust.

Door glass: sometimes black deposits will build up on the inside of the door glass. To remove this build up, rub gently with a plastic scourer pad moistened with water and detergent. Then use the damp and dry cloths as before. Hot glass cleaner is also available from your heater retailer.

Routine Maintenance Schedule

At beginning of the season and at least every 8 weeks during the season

- * Inspect and clean the flue system. To do this, remove the baffle plate and flue cowl, and clean out with a flue brush.
- * Check the painted surfaces. If there is any wear, for instance from cleaning or abrasion, touch up paint is available from your dealer.

At end of season

- * Inspect the door glass for any cracks and replace if necessary.
- * Inspect door rope and seals and replace if necessary.
- * Inspect firebox for wear or excessive corrosion.
- * Inspect firebricks where fitted and replace if broken.

- * Check that the air slide moves smoothly. If it is sticky, lubricate it with high temperature grease available from your local hardware store.

Creosote Build Up

When the heater is continually burnt with lower than normal fire temperatures, eg due to unseasoned wood, higher than acceptable amounts of smoke are produced which condense on the inside of the flue. This builds up as a black, tar-like deposit called creosote.

A thin layer of creosote inside the flue is normal and will not cause a problem. Once there is a layer more than 3mm thick, problems can occur.

1. If the layer is thick enough, it restricts the flue and can cause insufficient draw and even smoke spillage back into the house.
2. More seriously, creosote is combustible, and can ignite. A flue fire is easy to detect, involving a roaring sound, a vibration of the flue, and sometimes flames and sparks shoot out of the top of the flue.

To avoid creosote build up and the fires that may result, burn seasoned wood with the air control set to medium or high for most of the time.

To remove creosote when it does build up, remove the baffle plate and flue cowl, and use a flue brush to clean the flue system. To remove the baffle plate, slide the plate up on one side and then down around the brackets on the other.

In case of a flue fire, do not panic. Your flue system has been constructed to withstand high temperatures. Immediately close the air control down to its lowest setting. Do not open the door. Once the fire has extinguished, you should have your flue system inspected by a qualified service person.

CARING FOR THE ENVIRONMENT

Caring for our planet means reducing pollution and managing our resources intelligently. Every resource we use today we are borrowing from our future generations.

The key to successfully meeting our future energy requirements lies in our ability to manage existing resources wisely. Unlike fossil fuels such as oil, coal and gas, wood can be managed on a sustainable basis.

This is why wood is one of the wisest, most cost effective and environmentally efficient forms of home heating available today.

You can make a further positive contribution to the environment by following these important steps:-

Operating Your Heater

- * Always burn good, dry hardwood. This will yield the greatest amount of heat for the least amount of fuel.
- * Never burn green or unseasoned wood, or wood that is wet. This will waste energy, cause excessive smoke and reduce the performance of your wood heater.
- * Do not allow your wood to smoulder. Your fire should always burn brightly and cleanly. Check the flue occasionally to see if there is any excessive smoke.

Other Things You Can Do

- * Ensure your home is adequately insulated. This will reduce your energy requirements, and lessen your fuel bills, or the need to gather fuel. This in turn reduces pollution.
- * Do not overheat your home! If you feel hot even when wearing light clothing, then you are wasting energy.
- * Install ceiling fans in the main rooms. These are an excellent investment in year round comfort. Because hot air rises, ceiling fans push this hot air back closer to ground level to keep you warmer.



Barbeques Galore is a proud member of the Australian Home Heating Association

**WOOD HEATING IS
GOOD HEATING**

Norseman

NEED ACCESSORIES?

Your Barbeques Galore store also sells a range of attractive, good value accessories for your heater like mesh guards, toolsets and wood baskets.

Also, you can ask about maintenance products, firelighters, touch up paint, flue cleaning products and more.

For your nearest Barbeques Galore store call

1300 BARBEQUES

G.L.G. Australia Pty Ltd
Building A2, Campus Business Park
350-374 Parramatta Road
Homebush, NSW 2140

HINS-212F
04022026